



## Electronic Emission Notices

### **Federal Communications Commission (FCC) Statement**

This equipment has been tested and found to comply with the limits for a Class B digital device, pursuant to Part 15 of FCC Rules. These limits are designed to provide reasonable protection against harmful interference in a residential installation. This equipment generates, uses and can radiate radio frequency energy and, if not installed and used in accordance with instructions contained in this manual, may cause harmful interference to radio and television communications. However, there is no guarantee that interference will not occur in a particular installation.

If this equipment does cause harmful interference to radio or television reception, which can be determined by turning the equipment off and on, the user is encouraged to try to correct the interference by one or more of the following measures:

- REORIENT OR RELOCATE THE RECEIVING ANTENNA
- INCREASE THE SEPARATION BETWEEN THE EQUIPMENT AND THE RECEIVER
- CONNECT THE EQUIPMENT INTO AN OUTLET ON A CIRCUIT DIFFERENT FROM THAT OF THE RECEIVER
- CONSULT THE DEALER OR AN EXPERIENCED AUDIO/TELEVISION TECHNICIAN

**NOTE:** Connecting this device to peripheral devices that do not comply with Class B requirements, or using an unshielded peripheral data cable, could also result in harmful interference to radio or television reception.

The user is cautioned that any changes or modifications not expressly approved by the party responsible for compliance could void the user's authority to operate this equipment.

To ensure that the use of this product does not contribute to interference, it is necessary to use shielded I/O cables.

### **Copyright**

This manual is copyrighted with all rights reserved. No portion of this manual may be copied or reproduced by any means.

While every precaution has been taken in the preparation of this manual, no responsibility for errors or omissions is assumed. Neither is any liability assumed for damages resulting from the use of the information contained herein.

### **Trademarks**

All brand names, logos and registered trademarks mentioned are property of their respective owners.

---

---

# TABLE OF CONTENT

---

---

## INTRODUCTION

1	FEATURES OF MOTHERBOARD.....	1
	SPECIAL FEATURES OF MOTHERBOARD.....	2
2	SPECIFICATION .....	3
3	LAYOUT DIAGRAM & JUMPER SETTING.....	4

## HARDWARE INSTALLATION

1	INSTALL CPU .....	7
2	INSTALL MEMORY.....	8
3	EXPANSION CARDS.....	9

## CONNECTORS, HEADERS & JUMPERS SETTING

1	CONNECTORS.....	11
2	HEADERS.....	14
3	STARTING UP YOUR COMPUTER.....	17

## USEFUL SETUP

1	BIOS SETUP .....	18
2	DRIVER & FREE PROGRAM INSTALATION.....	34

## USEFUL HELP

1	HOW TO UPDATE BIOS .....	46
2	DEBUG PORT POST CODE .....	47
3	GLOSSARY .....	53

## Box Included Checklist

- Sapphire PC-AM3RS790G Motherboard
- Cable for ATA 133 IDE
- Sapphire Driver CD for Motherboard and Utilities
- Cable for Serial ATA II and Power cable
- Sapphire PC-AM3RS790G Motherboard User's Manual
- Rear External I/O Shield
- PCI-E X16 slot Switch Card

## Environmental Protection Announcement

Do not dispose this electronic device into the trash while discarding. To minimize pollution and ensure environment protection of mother earth, please recycle.



# Introduction

## Features of motherboard

The AMD790GX chipset motherboard series are based on the latest AMD790GX Chipset and the SB750 chipset which supports the innovative AMD Phenom™ II X3 processor and AMD Phenom™ II X4 processors. With an integrated low-latency high-bandwidth DDRIII memory controller and a highly-scalable Hyper Transport technology-based system bus up to HT 3.0. AMD790GX Platform Processor Chipset motherboard series deliver the outstanding system performance and professional desktop platform solution.

The AMD790GX Series motherboards support new generation Socket AM3 processors with an integrated DDRIII memory controller for Dual channel DDRIII800 / DDRIII 1066 / DDRIII 1333 Module up to 8GB, also provide DDRIII 128Mb GPU Memory. The motherboard is embedded with SB750 chipset of providing ULTRA ATA 133 connectors and Serial ATA2 with RAID 0, 1, 10,5 functions which support up to one IDE and six Serial ATA2 devices to accelerate hard disk drives and guarantee the data security without failure in advanced computing performance.

The AMD790GX motherboards provide 10/100/1000 LAN function with RTL8111CVC PCI-E Gigabit LAN which supports 10/100/1000Mbps data transfer rate. And the embedded 8-channel HD Audio CODEC is fully compatible with Sound Blaster Pro standards that offer you with the home cinema quality and satisfying software compatibility.

The AMD790GX Series motherboards deliver outstanding value and performance for gamers, with a true bandwidth design for Multi-GPU configurations. This high bandwidth architecture in the AMD 790GX chipset are with the flexibility for single or dual card configurations. The AMD 790GX chipset provides 2 x16@8 lane PCI Express 2.0 slots to support simultaneous operation of graphics cards for astonishing performance with brilliant and intense 3D graphics.

AMD790GX Series motherboard series offer two PCI-Express2.0x16 graphics slots. Two PCI-Express x16@ 8lane deliver up to 4Gbyte/sec data transfer rate at each relative direction. When PE4 installed switch card, the PE1 will doubled its bandwidth. Two PCI Express x1 I/O slot offers 1024 Mbyte/sec concurrently, over 7 times more bandwidth than PCI at 133Mbyte/sec, tackling the most demanding multimedia tasks nowadays .The AMD790GX motherboards also carry two 32-bit PCI slots guarantee the rich connectivity for the I/O peripheral devices. This motherboard support Hybrid CrossFireX function, the VGA Card on PE1 or PE4 will activate a Hybrid CrossFire with the onboard VGA Card, the performance will be increased 15% to 75%.

Embedded USB controllers as well as capability of expanding to 12 of USB2.0 functional ports delivering 480Mb/s bandwidth of rich connectivity, these motherboards meet the future USB demands which are also equipped with hardware monitor function on system to monitor and protect your system and maintain your non-stop business computing.

Some special features--- **CPU Thermal Throttling/ CPU Vcore X-shift / CPU Smart Fan / DeBug Port /OC-CON/ DIY Clear / Power On Button/ Reset Button.** in this motherboard are designed for power user to use the over-clocking function in more flexible ways. But please be caution that the over-clocking maybe causes the fails in system reliabilities. This motherboard provides the guaranteed performance and meets the demands of the next

generation computing. But if you insist to gain more system performance with variety possibilities of the components you choose, please be careful and make sure to read the detailed descriptions of these value added product features, please get them in the coming section.

## Special Features of Motherboard

### **CPU Thermal Throttling Technology**---(The CPU Overheat Protection Technology)

To prevent the increasing heat from damage of CPU or accidental shutdown while at high workload, the CPU Thermal Throttling Technology will force CPU to enter partially idle mode from 87.5% to 12.5% according to preset CPU operating temperature in BIOS (from 40°C to 90°C). When the system senses the CPU operating temperature reaching the preset value, the CPU operating bandwidth will be decreased to the preset idle percentage to cool down the processor. When at throttling mode the beeper sound can be optionally selected to indicate it is in working. (For detail operating please read Section 3-11 Bi-turbo Configuration)

### **CPU Smart Fan**---( The Noise Management System )

It's never been a good idea to gain the performance of your system by sacrificing its acoustics. CPU Smart Fan Noise Management System is the answer to control the noise level needed for now-a-day's high performance computing system. The system will automatically increase the fan speed when CPU operating loading is high, after the CPU is in normal operating condition, the system will low down the fan speed for the silent operating environment. The system can provide the much longer life cycle for both CPU and the system fans for game use and business requirements.

### **CPU Vcore X-Shift**--- (Shift to Higher Performance)

The CPU voltage can be adjusted up by 31 steps for the precisely over-clocking of extra demanding computing performance.

### **Debug Port** --- ( The Professional Hardware Diagnosis System )

Being bugged of abnormal system failure through the tossed and turned nights no more, the embedded Hardware Debug Port offers you the real-time visual system healthy for the demanding usage of computing. No more bugging by unknown system failure and no more time wasted in the first moment of 24-hour nonstop ping business computing, the embedded Debug Port will turn you into a well training hardware professional with the seeing system situation. (The Post Code please refer to appendix)

### **OC-CON** --- (High-polymer Solid Electrolysis Aluminum Capacitors)

The working temperature is from 55 degrees Centigrade below zero to 125 degrees Centigrade, OC-CON capacitors possess superior physical characteristics that can be while reducing the working temperature between 20 degrees Centigrade each time, intact extension 10 times of effective product operation lives, at not rising degrees Centigrade of working temperatures each time a relative one, life of product decline 10% only too.

**DIY Clear...** The CMOS button is to facilitate the clear CMOS process for power user overclocking function. The user can easily clear or restore CMOS setting by pressing the button without tacking trouble to remove the case and locate the jumper for clear CMOS .

**Power On Button...** You can easily start the computer by pressing down this button for a few seconds, without troubling yourself to locate the front panel jumpers to find the Power on jumper.

**Reset Button..:** You can easily restart the computer by pressing down this button for a few seconds, without troubling yourself to locate the front panel jumpers to find the reset jumper.

## Specification

Spec	Description
<b>Design</b>	<ul style="list-style-type: none"> <li>● ATX form factor 4 layers PCB size: 30.5cm x24.5cm</li> </ul>
<b>Chipset</b>	<ul style="list-style-type: none"> <li>● AMD790GX North Bridge Chipset</li> <li>● AMD SB750 South Bridge Chipset</li> </ul>
<b>CPU Socket AM3</b>	<ul style="list-style-type: none"> <li>● Support AMD AM3 processors: AMD Phenom™ II X3 and AMD Phenom™ II X4 processors</li> <li>● Support HT 3.0</li> </ul>
<b>Memory Socket</b>	<ul style="list-style-type: none"> <li>● 240-pin DDRIII Module socket x 4</li> <li>● Support 4pcs DDRIII 800/DDRIII 1066 /DDRIII 1333 Modules Expandable to 16GB</li> <li>● Dual channel supported</li> </ul>
<b>Expansion Slot</b>	<ul style="list-style-type: none"> <li>● 2pcs PCI-Express 2.0x16 by 8 lane</li> <li>● 2pcs PCI-Express 2.0 x1 slot</li> <li>● 32-bit PCI slot x 2pcs</li> </ul>
<b>Integrate IDE and Serial ATA2 RAID</b>	<ul style="list-style-type: none"> <li>● One IDE controllers support PCI Bus Mastering, ATA PIO/DMA and the ULTRA DMA 33/66/100/133 functions that deliver the data transfer rate up to 133 MB/s for 2 IDE Devices and for 6 Serial ATA 3Gb/s connectors with RAID 0, 1, 10,5 functions</li> </ul>
<b>Gigabit LAN</b>	<ul style="list-style-type: none"> <li>● Integrated RTL8111CVC PCI-E 10 / 100 / 1000 LAN.</li> <li>● Support Fast Ethernet LAN function of providing 10Mb/100Mb/1000 Mb/s data transfer rate</li> </ul>
<b>8 CH-Audio</b>	<ul style="list-style-type: none"> <li>● Realtek ALC888 Azalia 8-channel Audio Codec integrated</li> <li>● Support 8-channel 3D surround &amp; Positioning Audio</li> <li>● Audio driver and utility included</li> </ul>
<b>Sideport Memory</b>	<ul style="list-style-type: none"> <li>● Embedded DDR III 128Mb sideport memory</li> </ul>
<b>BIOS</b>	<ul style="list-style-type: none"> <li>● AMI 8MB Flash ROM BIOS</li> </ul>
<b>Multi I/O</b>	<ul style="list-style-type: none"> <li>● PS/2 keyboard and PS/2 mouse connectors</li> <li>● HDMI Connector / DVI Connector / VGA Connector</li> <li>● ESATA Connector x1</li> <li>● RJ-45 Connector x1</li> <li>● USB2.0 port x 4 and headers x 4</li> <li>● Audio connector x1 (8CH Audio)</li> <li>● Floppy disk drive connector x1 /Hard Disk Drive Connector x1</li> <li>● Serial port header x1</li> <li>● HDMI-SPDIF header x1</li> <li>● IR header x1</li> </ul>

# Layout Diagram & Jumper Setting

## Rear I / O for 790GX based motherboard

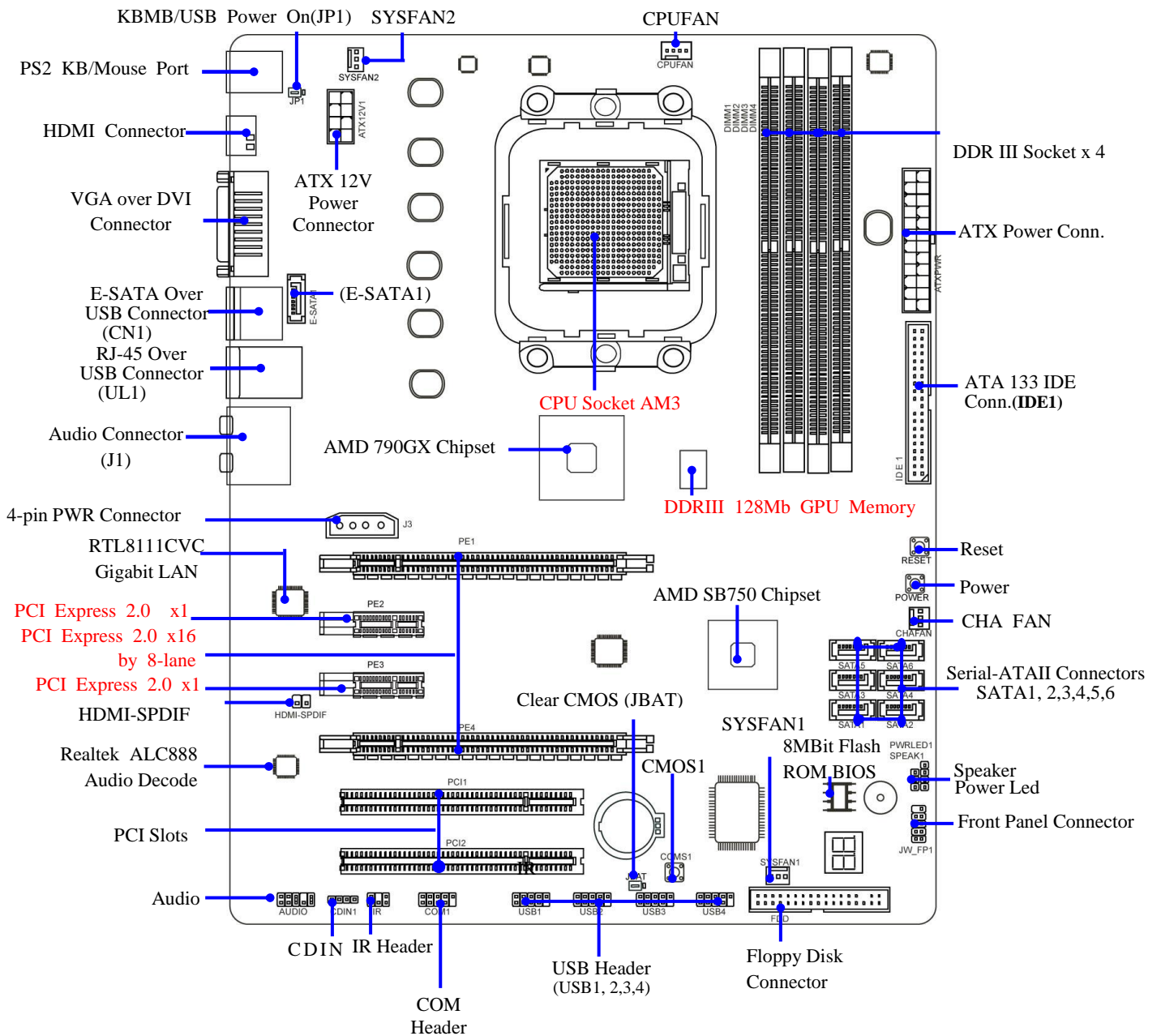
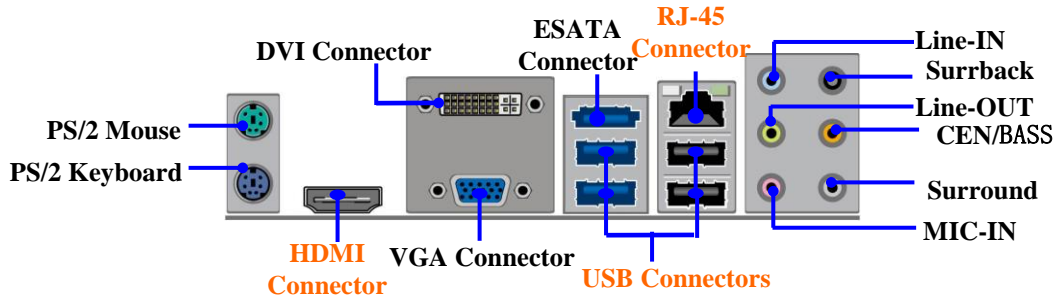

**Jumpers**

Jumper	Name	Description	Page
JP1	Keyboard/USB Power On Enabled/Disabled	3-pin Block	P.6
JBAT	Clear CMOS Header	3-pin Block	P.6

**Connectors**

Connector	Name	Description	Page
ATXPWR1	ATX Power Connector	24-pin Block	P.11
ATX12V	ATX 12V Power Connector	8-pin Block	P.11
KB	PS/2 Mouse & PS/2 Keyboard Connector	6-pin Female	P.12
CN1 for USB	USB2.0 Port Connector	4-pin Connector	P.12
UL1 for RJ45LAN	Gigabit LAN Port Connector	RJ-45 Connector	P.12
J3	Power Connector	4-Pin Block	P.12
J1	8-CH HD Audio Connector	6- phone jack Conn.	P.12
FDD	Floppy Driver Connector	34-pin Block	P.12
IDE1	Primary IDE Connector	40-pin Block	P.13
SATA1~SATA6, E-SATA1	Serial ATAII IDE Connectors	7-pin Connector	P.13
CN1 for ESATA	External Serial ATAII Connector	7-pin Connector	P.14
VGA1	Serial ATAII IDE Connectors	15-pin Connector	P.14
DVI	Serial ATAII IDE Connectors	29-pin Connector	P.14
HDMI	Serial ATAII IDE Connectors	19-pin Connector	P.14

**Headers**

Header	Name	Description	Page
AUDIO1	Front Panel SPEAKER, MIC header	9-pin Block	P.14
USB1, USB2,USB3,USB4	USB Port Headers	9-pin Block	P.14
SPEAK	PC Speaker connector	4-pin Block	P.15
PWR LED	Power LED	3-pin Block	P.15
JW_FP1 (Reset/IDE LED/Power Button)	Front Panel Header (including IDE activity LED/Reset switch / Power On Button lead)	9-pin Block	P.15
SYSFAN1/2, CHAFAN	FAN Headers	3-pin Block	P.15
CPUFAN	FAN Header	4-pin Block	P.15
CDIN1	CD Audio-In Header	4-pin Block	P.16
IR	IR infrared module Headers	5-pin Block	P.16
COM1	Serial Port COM1 Header	9-pin Block	P.16
HDMI-SPDIF	SPDIF Out header	2-pin Block	P.17

**Expansion Sockets**

Socket/Slot	Name	Description	Page
ZIF Socket AM3	CPU Socket	939-pin PGAB CPU Socket	P.7
DIMM1~4	DDRIII Module Socket	240-pin DDRIII Module Socket	P.8
PCI1~ PCI2	PCI Slots	32-bit PCI Local Bus Expansion slots	P.10
PE2,PE3	PCI-Express 2.0 x1Slot	PCI-Express 2.0 x1 Expansion Slots	P.10
PE1,PE4	PCI-Express 2.0x16 Slot	PCI-Express 2.0x16 Expansion Slots	P.10

## Hardware Installation

**WARNING!** Turn off your power when adding or removing expansion cards or other system components. Failure to do so may cause severe damage to both your motherboard and expansion cards.

### Hardware installation Steps

Before using your computer, you had better complete the following steps:

1. Check motherboard jumper setting
2. Install CPU and Fan
3. Install System Memory (DIMM)
4. Install Expansion cards
5. Connect IDE and Front Panel /Back Panel cable
6. Connect ATX Power cable
7. Power-On and Load Standard Default
8. Reboot
9. Install Operating System
10. Install Driver and Utility

### Checking Motherboard's Jumper Setting

#### (1) Keyboard/USB function Enabled/Disabled: JP1

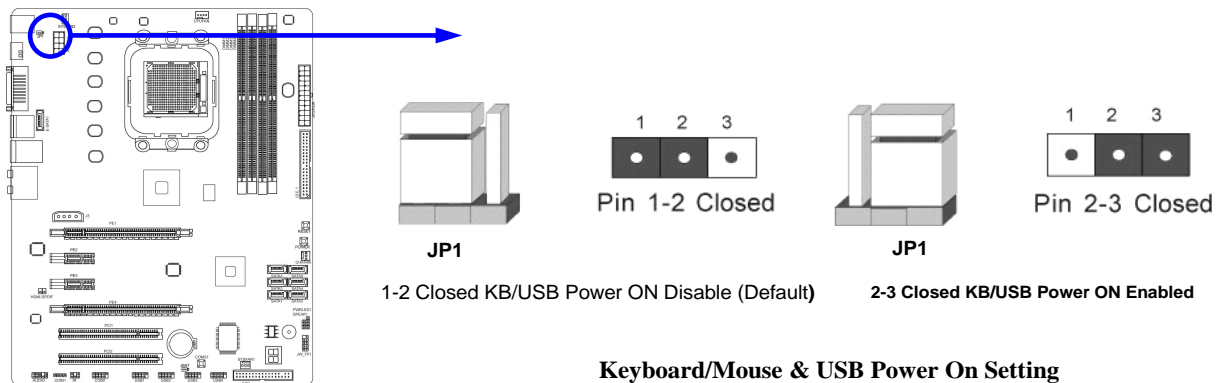

#### (2) CMOS RAM Clear (3-pin) : JBAT

A battery must be used to retain the motherboard configuration in CMOS RAM short 1-2 pins of JBAT to store the CMOS data.

To clear the CMOS, follow the procedure below:

1. Turn off the system and unplug the AC power
2. Remove ATX power cable from ATX power connector
3. Locate JBAT and short pins 2-3 for a few seconds
4. Return JBAT to its normal setting by shorting pins 1-2
5. Connect ATX power cable back to ATX power connector

**Note:** When should clear CMOS



1. *Troubleshooting*
2. *Forget password*
3. *After over clocking system boot fail*

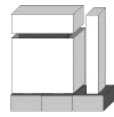
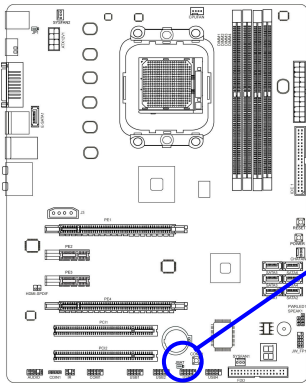

JBA1

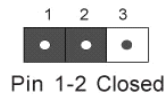

Pin 1-2 Closed

1-2 Closed Norma

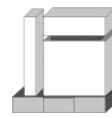

JBA1

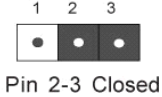

Pin 2-3 Closed

2-3 Closed Clear CMOS

CMOS RAM Clear Set

## Install CPU

### About AMD AM3 CPU Installation

This motherboard provides a socket AM2 surface mount, Zero Insertion Force (ZIF) socket, referred to as the mPGA939 socket supports AMD AM3 processor in the 939 Pin package utilizes Flip-Chip Pin Grid Array package technology.

The CPU that comes with the motherboard should have a cooling FAN attached to prevent overheating. If this is not the case, then purchase a correct cooling FAN before you turn on your system.

**WARNING!** Be sure that there is sufficient air circulation across the processor's heatsink and CPU cooling FAN is working correctly, otherwise it may cause the processor and motherboard overheat and damage, you may install an auxiliary cooling FAN, if necessary.

To install a CPU, first turn off your system and remove its cover. Locate the ZIF socket and open it by first pulling the level sideways away from the socket then upward to a 90-degree angle. Insert the CPU with the correct orientation as shown below. The notched corner should point toward the end of the level. Because the CPU has a corner pin for two of the four corners, the CPU will only fit in the orientation as shown.

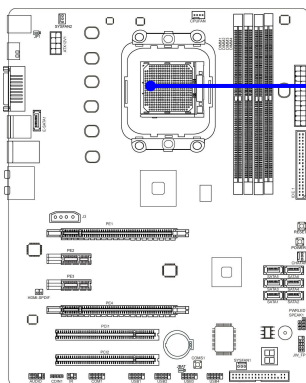

Golden A →



CPU ZIF mPGA939

When you put the CPU into the ZIF socket, No force required to insert of the CPU, and then press the level to locate position slightly without any extra force.

## Install Memory

This motherboard provides four 240-pin DDR III DUAL INLINE MEMORY MODULES (DIMM) socket for DDR III memory expansion available to maximum memory volume of 16 DDRIII SDRAM.

### Valid Memory Configurations

Bank	240-Pin DIMM	PCS	Maximum Capacity
Bank 0, 1 (DIMM1)	DDR III 800/DDR III 1066/ DDR III1333	X1	2GB
Bank 2, 3 (DIMM2)	DDR III 800/DDR III 1066/ DDR III1333	X1	2GB
Bank 4, 5 (DIMM3)	DDR III 800/DDR III 1066/ DDR III1333	X1	2GB
Bank 6, 7 (DIMM4)	DDR III 800/DDR III 1066/ DDR III1333	X1	2GB
Total	System Memory (Max2GB)	4	8GB

#### **Dual channel Limited!**

1. Dual channel function only supports when 2 DIMM Modules plug in either both DIMM1 & DIMM2 or DIMM3 & DIMM4, or four DIMM Modules plug in DIMM1~DIMM4.
2. DIMM1 & DIMM2, or DIMM3 & DIMM4 must be the same type, same size, same frequency for dual channel function.

Install DDR SDRAM modules to your motherboard is not difficult, you can refer to figure below to see how to install a 240-Pin DDRIII 800/DDRIII 1066/DDRIII 1333 SDRAM module.

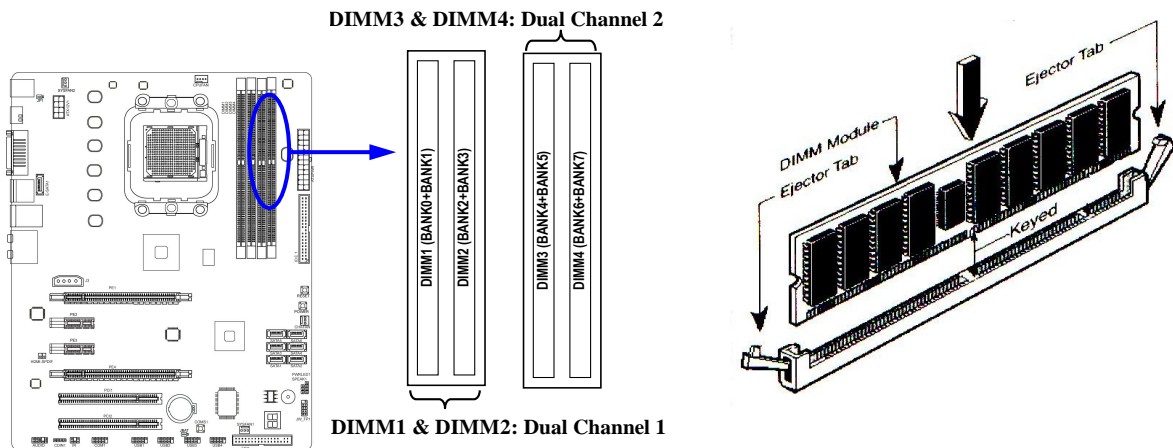

#### **NOTE!**

When you install DIMM module fully into the DIMM socket the eject tab should be locked into the DIMM module very firmly and fit into its indentation on both sides.

## Expansion Cards

**WARNING!** Turn off your power when adding or removing expansion cards or other system components. Failure to do so may cause severe damage to both your motherboard and expansion cards.

### Procedure for Expansion Card Installation

1. Read the documentation for your expansion card and make any necessary hardware or software setting for your expansion card such as jumpers.
2. Remove your computer's cover and the bracket plate on the slot you intend to use.
3. Align the card's connectors and press firmly.
4. Secure the card on the slot with the screen you remove above.
5. Replace the computer system's cover.
6. Set up the BIOS if necessary.
7. Install the necessary software driver for your expansion card.

### Assigning IRQs for Expansion Card

Some expansion cards need an IRQ to operate. Generally, an IRQ must exclusively assign to one use. In a standard design, there are 16 IRQs available but most of them are already in use.

### Standard Interrupt Assignments

IRQ	Priority	Standard function
0	N/A	System Timer
1	N/A	Keyboard Controller
2	N/A	Programmable Interrupt
3 *	8	Communications Port (COM2)
4 *	9	Communications Port (COM1)
5 *	6	Sound Card (sometimes LPT2)
6 *	11	Floppy Disk Controller
7 *	7	Printer Port (LPT1)
8	N/A	System CMOS/Real Time Clock
9 *	10	ACPI Mode when enabled
10 *	3	IRQ Holder for PCI Steering
11 *	2	IRQ Holder for PCI Steering
12 *	4	PS/2 Compatible Mouse Port
13	N/A	Numeric Data Processor
14 *	5	Primary IDE Channel
15 *	1	Secondary IDE Channel

\* These IRQs are usually available for ISA or PCI devices.

### Interrupt Request Table for This Motherboard

Interrupt request are shared as shown the table below:

	INT A	INT B	INT C	INT D	INT E	INT F	INT G	INT H
Slot 1	√							
Slot 2		√						
Onboard USB 3			√					
HD Audio/MC97			√					

**NOTE!**

If using PCI cards on shared slots, make sure that the drivers support "Shared IRQ" or that the cards don't need IRQ assignments. Conflicts will arise between the two PCI groups that will make the system unstable or cards inoperable.

## PCI Express2.0 Slot

Two PCI-Express2.0 x16@8 lane graphic slot offer 4Gbyte/sec data transfer rate at each relative direction and up to 8Gbyte/sec concurrent bandwidth at full speed. Two x1 PCI Express Slot offer 1024Mbyte/sec concurrently over 7 times more bandwidth than PCI at 133Mbyte/sec, tackling the most demanding multimedia tasks nowadays. Fully compliant to the *PCI Express Base Specification revision2.0*, support PCI Express VGA card, and other PCI Express device. This motherboard support Hybrid CrossFireX function.

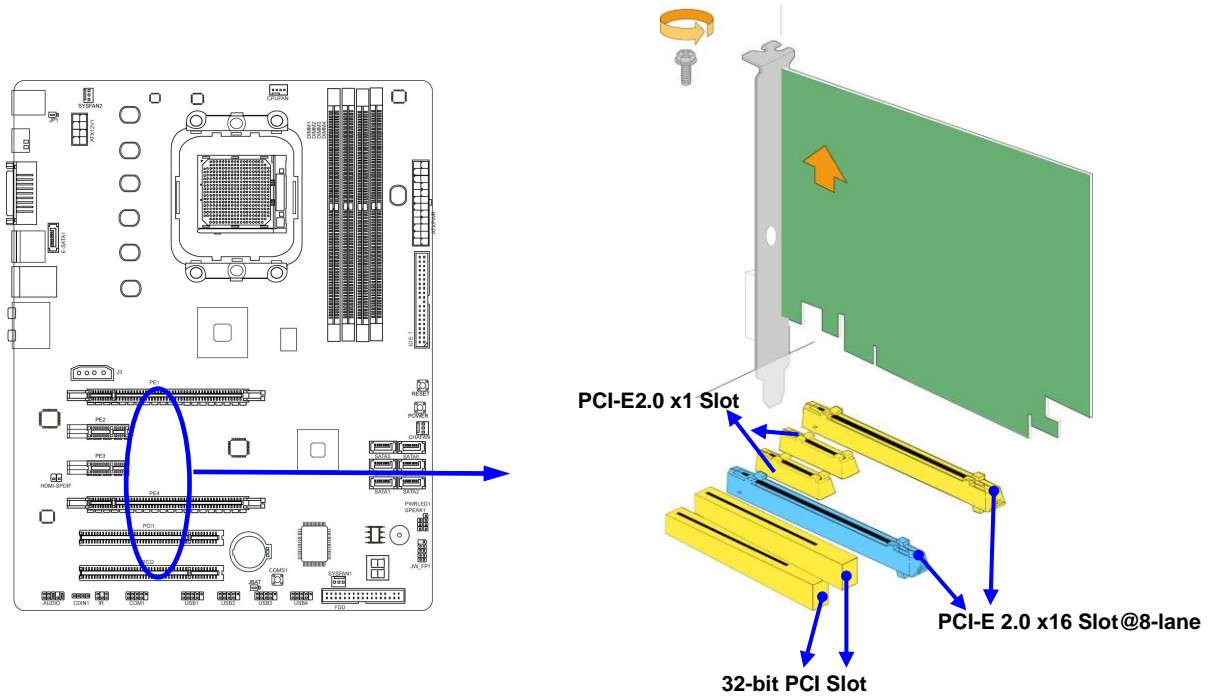

## PCI Express Switch Card

Install PCI-E Switch Card to PCI-Express2.0 x16 graphics slot can double PCI-E X16 VGA card installed transfer rate up to 16 lane; 16Gbyte/sec

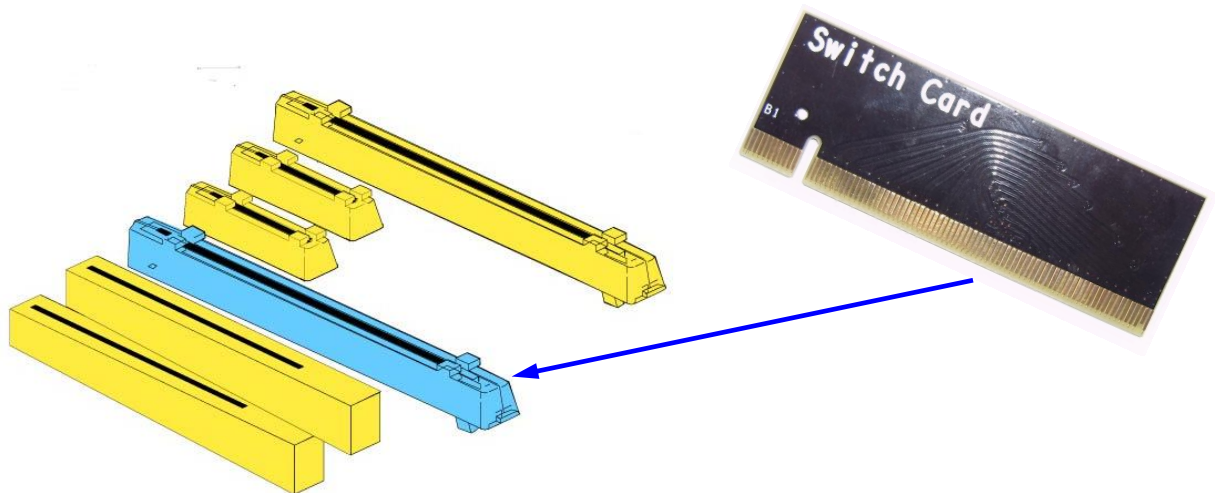

# Connectors, Headers & Jumper Setting

## Connectors

### (1) Power Connector (24-pin block) : ATXPWR1

ATX Power Supply connector: This is a new defined 24-pins connector that usually comes with ATX case. The ATX Power Supply allows using soft power on momentary switch that connect from the front panel switch to 2-pins Power On jumper pole on the motherboard. When the power switch on the back of the ATX power supply turned on, the full power will not come into the system board until the front panel switch is momentarily pressed. Press this switch again will turn off the power to the system board.

\*\* We recommend that you use an ATX 12V Specification 2.0-compliant power supply unit (PSU) with a minimum of 350W power rating. This type has 24-pin and 4-pin power plugs.

\*\* If you intend to use a PSU with 20-pin and 4-pin power plugs, make sure that the 20-pin power plug can provide at least 15A on +12V and the power supply unit has a minimum power rating of 350W. The system may become unstable or may not boot up if the power is inadequate.

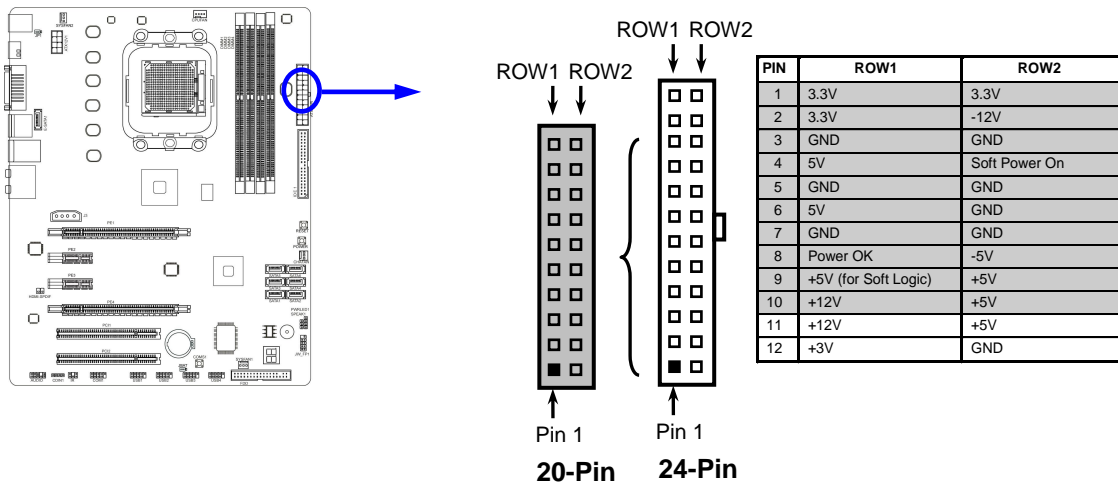

### (2) ATX 12V Power Connector (8-pin block) : ATX12V1

This is a new defined 8-pins connector that usually comes with ATX Power Supply. The ATX Power Supply which fully supports Socket AM3 processor must including this connector for support extra 12V voltage to maintain system power consumption. Without this connector might cause system unstable because the power supply can not provide sufficient current for system.

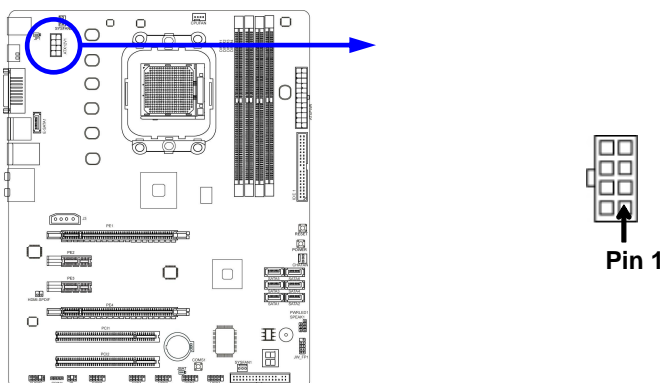

**(3) PS/2 Mouse & PS/2 Keyboard Connector: KB**

The connectors are for PS/2 keyboard and PS/2 Mouse.

**(4) USB Port connector: CN1/ UL1 for USB**

The connectors are 4-pin connector that connects USB devices to the system board.

**(5) LAN Port connector: UL1 for RJ45 LAN**

The connector is standard RJ45 connector for Network. It supports 10M/100Mb/1000Mbps data transfer rate

**(6) Large 4-Pin Power Connector : J3 Power Connector**

The connectors are 4-pin connector that supports extra 12V / 5V power to your system

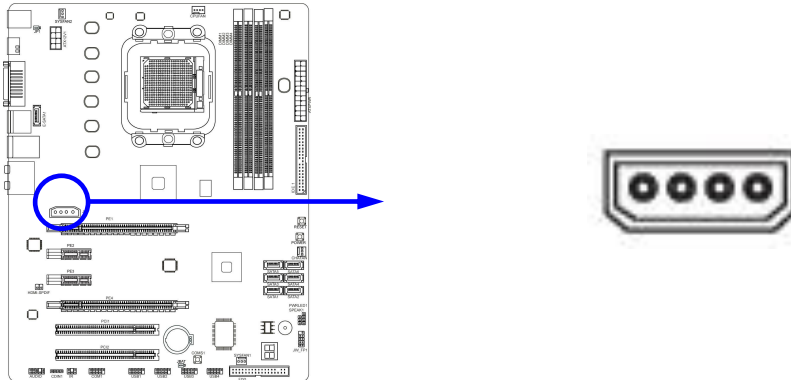

**(7) Audio Line-In, Lin-Out, MIC, RS-Out, CS-Out, SS-Out connector : J1**

These Connectors are 6 Phone-Jack for LINE-OUT, LINE-IN, MIC, RS-Out, CS-Out , SS-Out audio connections.

- Line-in : (BLUE)** Audio input to sound chip
- Line-out : (GREEN)** Audio output to speaker
- MIC : (PINK)** Microphone Connector
- RS-OUT : (BLACK)** Rear-Surround audio output
- CS-OUT : (ORANGE)** Center/ Subwoofer audio output
- SS-OUT: (GRAY)** Side-Surround audio output

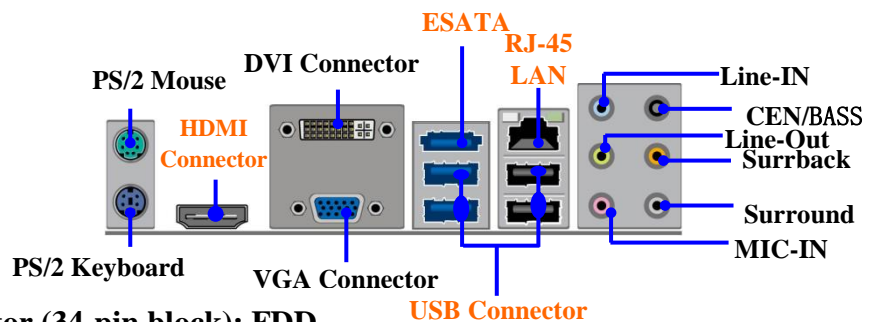
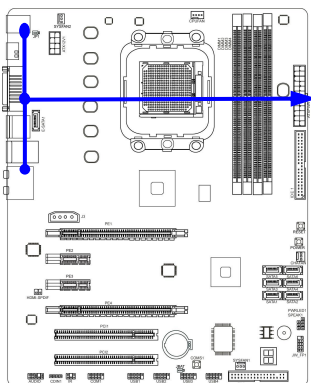

**(8) Floppy drive Connector (34-pin block): FDD**

This connector supports the provided floppy drive ribbon cable. After connecting the single plug end to motherboard, connect the two plugs at other end to the floppy drives.

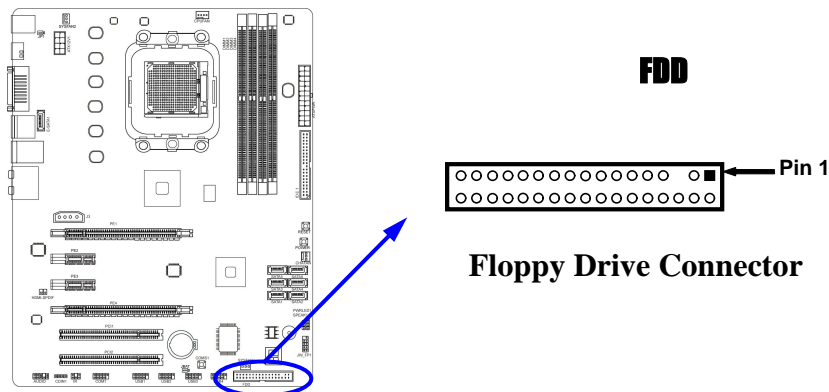

**(9) Primary IDE Connector (40-pin block): IDE1**

This connector supports the provided IDE hard disk ribbon cable. After connecting the single plug end to motherboard, connect the two plugs at other end to your hard disk(s). If you install two hard disks, you must configure the second drive to Slave mode by setting its jumpers accordingly. Please refer to the documentation of your hard disk for the jumper settings.

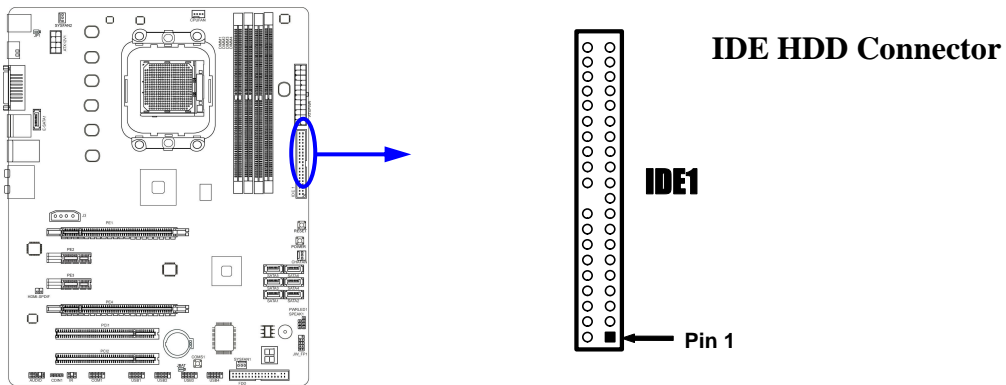

- Two hard disks can be connected to each connector. The first HDD is referred to as the “Master” and the second HDD is referred to as the “Slave”.
- For performance issues, we strongly suggest you don’t install a CD-ROM or DVD-ROM drive on the same IDE channel as a hard disk. Otherwise, the system performance on this channel may drop.

**(10) Serial-ATAII Port connector:SATA1~SATA6; E-SATA1**

This connector supports the provided Serial ATA2 IDE hard disk cable to connecting the motherboard with serial ATAII hard disk. E-SATA1 is not for SATA harddrive ,it is only for connecting to one of the SATA device from SATA1~SATA6 to activate the ESATA connector for SATA cable connected to rear I/O panel.

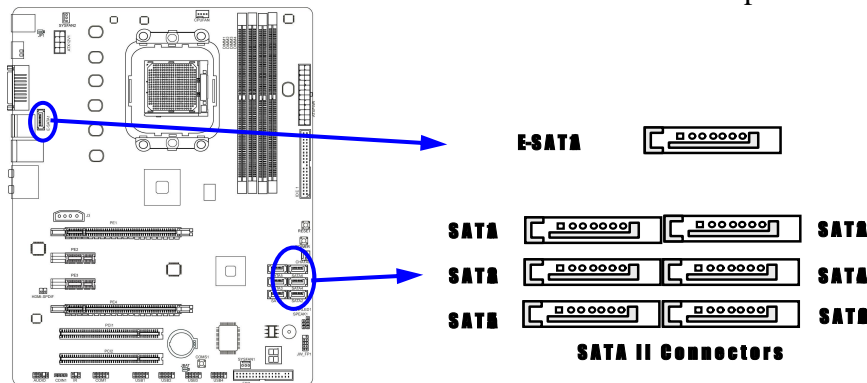

**(11) ESATA Port: CN1 for ESATA**

This connector supports the External Serial ATA2 (ESATA) enable the full SATA interface speed outside the chassis, up to 3Gb/s. The ESATA port can be enabled only when the E-SATA 1 is connected to one of SATA 1~SATA6.

**(12) D-Sub 15-pin Connector: VGA1**

VGA is the 15-pin D-Subminiature female connector; it is for the display devices, such as the CRT monitor, LCD monitor and so on.

**(13) Digital Visual Interface: DVI**

This interface standard designed to maximize the visual quality of digital display devices such as flat panel LCD computer displays and digital projectors.

**(14) High-Definition Multimedia Interface: HDMI**

This point-to-point interface is for audio and video signals designed as a single-cable solution for home theater and consumer electronics equipment.

## Headers

**(1) Line-Out/MIC Header for Front Panel (9-pin): AUDIO1**

These headers connect to Front Panel Line-out, MIC connector with cable.

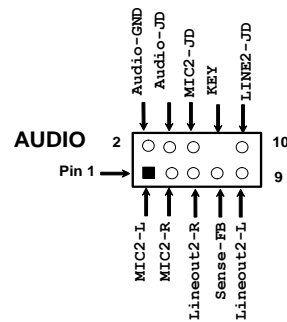
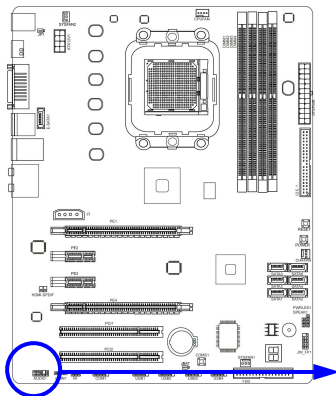

Line-Out, MIC Headers

**(2) USB Port Headers (9-pin): USB1/USB2/USB3/USB4**

These headers are used for connecting the additional USB port plug. By attaching an option USB cable, your can be provided with two additional USB plugs affixed to the back panel.

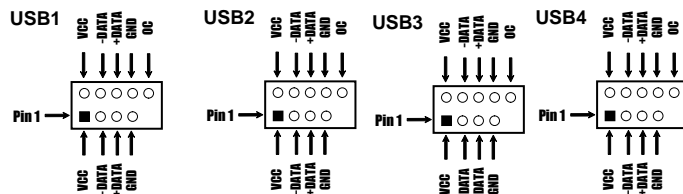
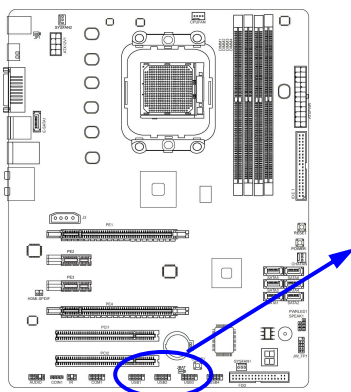

USB Port Headers



**(3) Speaker connector: SPEAK**

This 4-pin connector connects to the case-mounted speaker. See the figure below.

**(4) Power LED: PWR LED**

The Power LED is light on while the system power is on. Connect the Power LED from the system case to this pin.

**(5) IDE Activity LED: HD LED**

This connector connects to the hard disk activity indicator light on the case.

**(6) Reset switch lead: RESET**

This 2-pin connector connects to the case-mounted reset switch for rebooting your computer without having to turn off your power switch. This is a preferred method of rebooting in order to prolong the life of the system's power supply. See the figure below.

**(7) Power switch: PWR BTN**

This 2-pin connector connects to the case-mounted power switch to power ON/OFF the system.

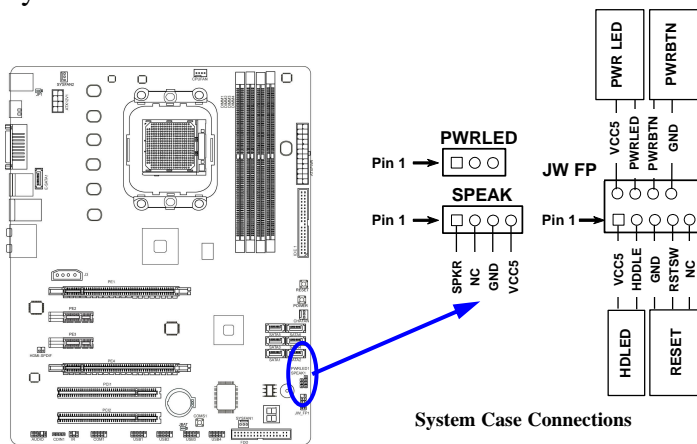

**(8) FAN Power Headers: SYSFAN1, SYSFAN2, CHAFAN (3-pin), CPUFAN (4-pin)**

These connectors support cooling fans of 350mA (4.2 Watts) or less, depending on the fan manufacturer, the wire and plug may be different. The red wire should be positive, while the black should be ground. Connect the fan's plug to the board taking into consideration the polarity of connector.

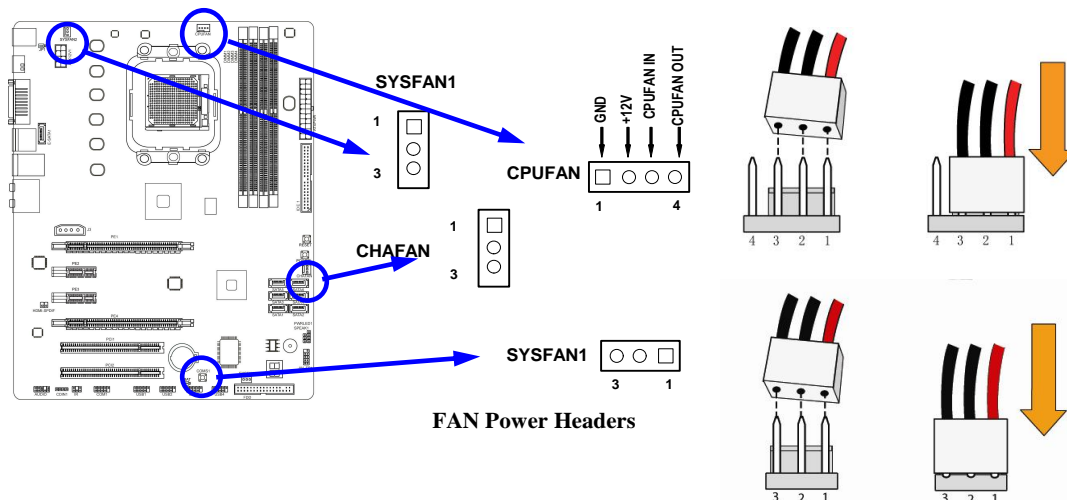

**(9) CD Audio-In Headers (4-pin): CDIN1**

CDIN are the connectors for CD-Audio Input signal. Please connect it to CD-ROM CD-Audio output connector.

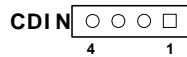
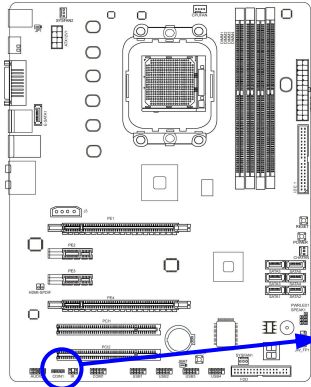

**CD Audio Headers**

**(10) IR infrared module Headers (5-pin): IR**

This connector supports the optional wireless transmitting and receiving infrared module. You must configure the setting through the BIOS setup to use the IR function.

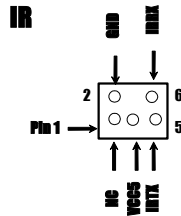
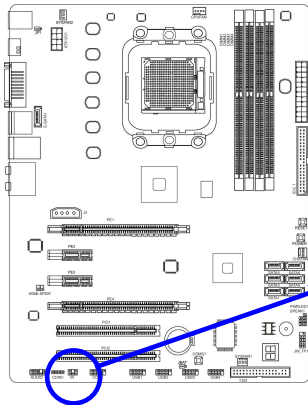

**IR infrared module Headers**

**(11) Serial COM Port header: COM1**

COM1 is the 9-pin block pin-header. The On-board serial port can be disabled through BIOS SETUP. Please refer to Chapter 3 “INTEGRATED PERIPHERALS SETUP” section for more detail information

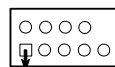
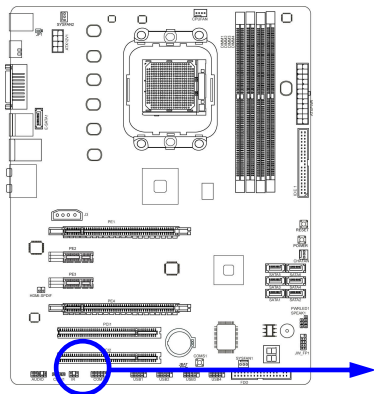

**Pin**

**Serial COM Port Block**

**(12) HDMI-SPDIF Out header: SPDIF Out**

The SPDIF output is capable of providing digital audio to external speakers or compressed AC3 data to an external Dolby digital decoder. Use this feature only when your stereo system has digital input function. Some of the VGA Card need connect SPDIF-IN Connector, so its HDMI Port can make sounds .

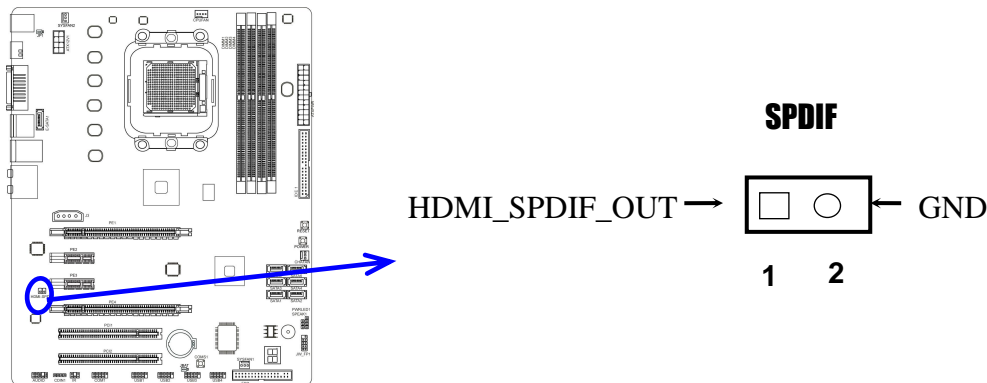
**Starting Up Your Computer**

1. After all connection are made, close your computer case cover.
2. Be sure all the switch are off, and check that the power supply input voltage is set to proper position, usually in-put voltage is 220V~240V or 110V~120V depending on your country's voltage used.
3. Connect the power supply cord into the power supply located on the back of your system case according to your system user's manual.
4. Turn on your peripheral as following order:
  - a. Your monitor.
  - b. Other external peripheral (Printer, Scanner, External Modem etc...)
  - c. Your system power. For ATX power supplies, you need to turn on the power supply and press the ATX power switch on the front side of the case.
5. The power LED on the front panel of the system case will light. The LED on the monitor may light up or switch between orange and green after the system is on. If it complies with green standards or if it is has a power standby feature. The system will then run power-on test. While the test is running, the BIOS will alarm beeps or additional message will appear on the screen.

If you do not see any thing within 30 seconds from the time you turn on the power. The system may have failed on power-on test. Recheck your jumper settings and connections or call your retailer for assistance.

6. During power-on, press <Delete> key to enter BIOS setup. Follow the instructions in BIOS SETUP.
7. **Power off your computer:** You must first exit or shut down your operating system before switch off the power switch. For ATX power supply, you can press ATX power switching after exiting or shutting down your operating system. If you use Windows 9X, click "Start" button, click "Shut down" and then click "Shut down the computer?" The power supply should turn off after windows shut down.

## Useful Setup

### BIOS Setup

The BIOS is a program located on a Flash Memory on the motherboard. This program is a bridge between motherboard and operating system. When you start the computer, the BIOS program will gain control. The BIOS first operates an auto-diagnostic test called POST (power on self test) for all the necessary hardware, it detects the entire hardware device and configures the parameters of the hardware synchronization. Only when these tasks are completed done it gives up control of the computer to operating system (OS). Since the BIOS is the only channel for hardware and software to communicate, it is the key factor for system stability, and in ensuring that your system performance as its best.

In the BIOS Setup main menu of Figure 3-1, you can see several options. We will explain these options step by step in the following pages of this chapter, but let us first see a short description of the function keys you may use here:

- Press <Esc> to quit the BIOS Setup.
- Press ↑↓←→ (up, down, left, right) to choose, in the main menu, the option you want to confirm or to modify.
- Press <F10> when you have completed the setup of BIOS parameters to save these parameters and to exit the BIOS Setup menu.
- Press <+>/<-> keys when you want to modify the BIOS parameters for the active option.
- Press Home to go to the top of screen; press End to go to the bottom of screen.
- Press Enter to go to sub screen.

### Entering Setup

Power on the computer and by pressing <Del> immediately allows you to enter Setup. If the message disappears before your respond and you still wish to enter Setup, restart the system to try again by turning it OFF then ON or pressing the “RESET” button on the system case. You may also restart by simultaneously pressing <Ctrl>, <Alt> and <Delete> keys. If you do not press the keys at the correct time and the system does not boot, an error message will be displayed and you will again be asked to

**Press <Del> to enter Setup**

### Getting Help

#### Main Menu

The on-line description of the highlighted setup function is displayed at the bottom of the screen.

#### Status Page Setup Menu/Option Page Setup Menu

Press F1 to pop up a small help window that describes the appropriate keys to use and the possible selections for the highlighted item. To exit the Help Window, press <Esc>.

## The Main Menu

Once you enter AMI BIOS Setup Utility, the Main Menu (Figure 3-1) will appear on the screen. The Main Menu allows you to select from 12 setup functions and 2 exit choices. Use arrow keys to select among the items and press <Enter> to accept or enter the sub-menu.

CMOS Setup Utility-Copyright (C)1985-2005 American Megatrends. Inc.

<b>Standard BIOS Features</b> Advanced BIOS Features Advanced Chipset Features Integrated Peripherals Power Management Features Miscellaneous Control PC Health Status	Thermal Throttling Option Power User Overclock Settings Password Settings Load Optimal Defaults Load Standard Defaults Save Changes and Exit Discard Changes and Exit
↑↓→←: Move Enter: Select +/-/: Value F10: Save ESC:Exit F1:General Help F5: Previous Values F6: Fail-Safe Defaults F7: Optimal Defaults	
V02.64 (C) Copyright 1985-2008, American Megatrends. Inc.	

Figure 3-1

### Standard CMOS Features

Use this Menu for basic system configurations.

### Advanced BIOS Features

Use this menu to set the Advanced Features available on your system.

### Advanced Chipset Features

Use this menu to change the values in the chipset registers and optimize your system's performance.

### Integrated Peripherals

Use this menu to specify your settings for integrated peripherals.

### Power Management Features

Use this menu to specify your settings for power management.

### Miscellaneous Control

Use this menu to specify your settings for **Miscellaneous Control**.

### PC Health Status

This entry shows your PC health status.

### Power User Overclock Settings

Use this menu to specify your settings (frequency, Voltage) for overclocking demand.

### CPU Thermal Throttling Setting

The selection is set for activating the active CPU Thermal Protection by flexible CPU loading adjustment in the range of temperature you define.

### Load Standard Defaults

This menu uses a minimal performance setting, but the system would run in a stable way.

**Load Optimal Defaults**

Use this menu to load the BIOS default values these are setting for optimal performances system operations for performance use.

**Password Settings**

This entry for setting Supervisor password and User password

**Save Changes and Exit**

Save CMOS value changes to CMOS and exit setup.

**Discard Changes and Exit**

Abandon all CMOS value changes and exit setup.

**Standard BIOS Features**

The items in Standard CMOS Setup Menu are divided into several categories. Each category includes no, one or more than one setup items. Use the arrow keys to highlight the item and then use the <+> or <-> and numerical keyboard keys to select the value you want in each item.

CMOS Setup Utility-Copyright(C)1985-2005 American Megatrends. Inc.  
Standard BIOS Features

Language	English	Help Item
System Date	Wed 01/07/2009	Select the Current default language used by the BIOS
System Time	22 : 46 : 33	
Primary IDE Master	Not Detected	
Primary IDE Slave	Not Detected	
Primary SATA Channel 5	Not Detected	
Primary SATA Channel 6	Not Detected	
Primary SATA Channel 1	Not Detected	
Primary SATA Channel 3	Not Detected	
Primary SATA Channel 2	Not Detected	
Primary SATA Channel 4	Not Detected	
FLOPPY A	1.44MB, 3 $\frac{1}{2}$ //	
System Memory		
Size: 768 MB		
↑↓→← Move Enter:Select +/-/PU/PD:Value F10:Save ESC:Exit F1:General Help F5: Previous Values F6: Fail-Safe Defaults F7: Optimal Defaults		

**Language**

Use this item to select the current default language used in BIOS. The Optional settings are: Chinese (GB): English.

**System Date**

The date format is <day><month><date><year>.

- Day** Day of the week, from Sun to Sat, determined by BIOS. Read-only.
- Month** The month from Jan. through Dec.
- Date** The date from 1 to 31 can be keyed by numeric function keys.
- Year** The year depends on the year of the BIOS.

**System Time**

The time format is <hour><minute><second>.

**Primary IDE Master / Slave**

**SATA Channel 1, 2, 3, 4, 5, 6**

While entering setup, BIOS auto detect the presence of IDE devices. This displays the status of auto detection of IDE devices.

**Type:** The optional settings are: Not Installed; Auto; CD/DVD and ARMD

**LBA/Large Mode:** The optional settings are Auto; Disabled.

**Block (Multi-Sector Transfer):** The optional settings are: Disabled and Auto.

**PIO Mode: the optional settings are:** Auto, 0, 1, 2, 3 and 4.

**DMA MODE:** the optional settings are Auto, SWDMAn, MWDMAAn , UDMAAn.

**S.M.A.R.T.:** This option allows you to enable the HDD S.M.A.R.T Capability (Self-Monitoring, Analysis and Reporting Technology). The optional settings are Auto; Disabled; and ENABLED.

**32 Bit Data Transfer:** the optional settings are: Disabled and Enabled.

**Floppy A**

This item is for specific floppy disk drive settings. Select according to the specification of the floppy disk you use.

**System Memory**

This item will show information about the memory modules(s) installed.

**Advanced BIOS Feature**

CMOS Setup Utility-Copyright(C)1985-2005 American Megatrends. Inc.  
Advanced BIOS Features

Advanced Settings	Help Item
<p>WARNING: Setting wrong values in below sections May cause system to malfunction</p>	
<p>CPU Configuration <span style="float:right">Press Enter</span>            Boot Sector Virus Protection <span style="float:right">Disabled</span>            Removable Drives <span style="float:right">Press Enter</span>            Quick Boot <span style="float:right">Enabled</span>            1<sup>ST</sup> BOOT Device <span style="float:right">1<sup>st</sup> Floppy Drive</span>            Boot up Num-Lock <span style="float:right">On</span>            ACPI APIC Support <span style="float:right">Enabled</span>            MPS Revision <span style="float:right">1.4</span>            Quiet Boot <span style="float:right">Disabled</span></p>	<p>Configure CPU</p>
<p>↑↓←→ Move Enter:Select +/-/PU/PD:Value F10:Save ESC:Exit F1:General Help            F5: Previous Values F6: Fail-Safe Defaults F7: Optimal Defaults</p>	

**Boot Sector Virus Protection**

The selection Allow you to choose the VIRUS Warning feature for IDE Hard Disk boot sector protection. If this function is enabled and someone attempt to write data into this area, BIOS will show a warning message on screen and alarm beep.

**Disabled** (default) No warning message to appear when anything attempts to access the boot sector or hard disk partition table.

**Enabled** Activates automatically when the system boots up causing a warning message to appear when anything attempts to access the boot sector of hard disk partition table.

### Removable Drives

Use this item to specify the boot device priority sequence from available removable drives.

### Quick Boot

Allows BIOS to skip certain tests while booting. This will decrease the needed to boot the system.

### 1<sup>st</sup> Boot Device

Specify the boot sequence from the available devices. A device enclosed in parenthesis has been disabled in corresponding type menu.

### Boot Up NumLock Status

The default value is On.

**On** (default) Keypad is numeric keys.

**Off** Keypad is arrow keys.

### ACPI APIC Support

Include ACPI APIC table pointer to RSDT pointer list.

### MPS Revision

This option is only valid for multiprocessor motherboards as it specifies the version of the Multiprocessor Specification (MPS) that the motherboard will use.

### Quiet Boot

The optional settings are Enabled and Disable.

Disabled: Display normal POST message.

Enabled: Displays OME logo instead of POST message.

## Advanced Chipset Features

The Advanced Chipset Features Setup option is used to change the values of the chipset registers. These registers control most of the system options in the computer.

CMOS Setup Utility-Copyright(C)1985-2005 American Megatrends. Inc.  
Advanced Chipset Features

Memory Configuration	Press Enter	Help Item
Internal Graphics Configurations	Press Enter	
PCI Express Configuration	Press Enter	
HDMI Audio	<b>HDMI</b>	<b>Options</b>
NB Power Management Feature	Auto	Auto
Primary Video Controller	PCI-GFX0-GPP-IGFX	HDMI
		DVI
↑↓→← Move Enter:Select +/-/PU/PD:Value F10:Save ESC:Exit F1:General Help F5: Previous Values F6: Fail-Safe Defaults F7: Optimal Defaults		

### NB Power Management Features

Dynamic clock gating for IOC/NT/MCU/CFG.

### HDMI Audio

Use this item to select HDMI audio, the optional settings are: Auto, HDMI and DVI.

### Primary Video Controller

This item is for user to choose primary video controller.



## Memory Configuration

CMOS Setup Utility-Copyright(C)1985-2005 American Megatrends. Inc.

### Memory Configuration

DRAM Timing Mode	Auto	Help Item
Memory CLK:	533MHz, N/A	
CAS Latency (Tcl):	7 CLK, N/A	Options
RAS/CAS Delay (Trcd):	7 CLK, N/A	DCT0
Row Precharge Time (Trp):	7 CLK, N/A	DCT1
Min Active RAS (Trrd):	20 CLK, N/A	Both
RAS/RAS Delay (Trrd)	4 CLK, N/A	
Row Cycle (Trc)	21CLK, N/A	
Write Recover Time (Twr)	8 CLK, N/A	
Bank Interleaving	Auto	
Channel Interleaving	XOK of Address Bits	
Enabled clock to AC1 DIMMs	Disabled	
Mem CLK Tristate C3/ATL VID	Disabled	
Memory Hole Remapping	Enabled	
DCI Unganged Mode	Always	
Power Down Enabled	Enabled	
Power Down Mode	Channel	
↑↓→← Move Enter:Select +/-/PU/PD:Value F10:Save ESC:Exit F1:General Help F5: Previous Values F6: Fail-Safe Defaults F7: Optimal Defaults		

### Bank Interleaving

Use this item to enable bank memory interleaving.

### Enable Clock to ALL DIMMs

Enable unused clocks to DIMMS when memory slots are not populated.

### Mem CLK Tristate during C3 and Alt VID.

Enable and disable Mem CLK Tri-stating during C3 and Alt VID

### Memory Hole Remapping

Enable Memory Remapping around Memory Hole.

### DCT Unganged Mode

This allows selection of unganged DRAM MODE (64- bit width).

Auto=Ganged Mode; Always= Unganged Mode.

### Power Down Enable

Enable or Disable power down mode.

### Power Down Mode

Set the DDR power down mode. The optional settings are Channel; Chipset.

## Internal Graphics Configurations

CMOS Setup Utility-Copyright(C)1985-2005 American Megatrends. Inc.  
Internal Graphics Configurations

Internal Graphics Configurations		Help Item
Internal Graphics Mode	UMA+SIDEPORT	Options
UMA Frame Buffer Size	Auto	Disabled
		UMA
		SIDEPORT
		UMA+SIDEPORT
GFX Engine Clock Override	Enabled	
GFX Engine Clock	700	
Surround View	Disabled	
FB Location	Above 4G	
↑↓→← Move Enter:Select +/-/PU/PD:Value F10:Save ESC:Exit F1:General Help F5: Previous Values F6: Fail-Safe Defaults F7: Optimal Defaults		

### UMA Frame Buffer Size

The optional settings are: Auto; 32MB; 64 MB; 128 MB; 256 MB and 512 MB.

### Surround View

The item is for Hybrid CrossFire function. The optional settings are: Enabled; Disabled.

## PCI Express Configuration

CMOS Setup Utility-Copyright(C)1985-2005 American Megatrends. Inc.  
PCIExpress Configuration

PCI Express Configuration		Help Item
GFX Dual slot configuration	Auto	Options
Gfx Slots Power Limit. W	25	Auto
Port # 02 Features	Press Enter	Enabled
Port # 03 Features	Press Enter	Disabled
Port #04 Features	Press Enter	
Port #05 Features	Press Enter	
Port #07 Features	Press Enter	
Port #09 Features	Press Enter	
Port #10 Features	Press Enter	
NB-SB Port Features	Press Enter	
↑↓→← Move Enter:Select +/-/PU/PD:Value F10:Save ESC:Exit F1:General Help F5: Previous Values F6: Fail-Safe Defaults F7: Optimal Defaults		

### Port #02 Features ~ Port #03 Features

Press Enter and set values in the sub-items as Gen2 High Speed Mode, Link ASPM, Link width and Slot Power Limit,w.

### Port #04 Features~ Port #10 Features

Press Enter and set values in the sub-items as Gen2 High Speed Mode, and Link ASPM.

### NB-SB Port Features

Press Enter and set values in the sub-items as NB-SB Link ASPM,;NP NB-SB VC1 Traffic Support and Link Width.

## Integrated Peripherals

CMOS Setup Utility-Copyright(C)1985-2005 American Megatrends. Inc.  
Integrated Peripherals

Onboard SATA Device	Press Enter	Help Item
Onboard Device Control	Press Enter	
Super IO Configuration	Press Enter	
↑↓→← Move Enter: Select +/-/PU/PD: Value F10:Save ESC: Exit F1:General Help F5: Previous Values F6: Fail-Safe Defaults F7: Optimal Defaults		

## Onboard SATA Device

CMOS Setup Utility-Copyright(C)1985-2005 American Megatrends. Inc.  
Onboard SATA Device

Onchip SATA Channel	Enter	Help Item
Onchip SATA Type	Native IDE	
SATA IDE Combined Mode	Enabled	Select the time out value for detecting ATA/ATAPI device(s)
PATA Channel Config	SATA as Secondary	
Onboard PCI IDE Controller	Both	
Hard Disk Write Protect	Disabled	
IDE Detect Time Out(Sec)	35	
ATA (PI) 80 Pin Cable Detect	Host & Device	
↑↓→← Move Enter:Select +/-/PU/PD:Value F10:Save ESC:Exit F1:General Help F5: Previous Values F6: Fail-Safe Defaults F7: Optimal Defaults		

### OnChip SATA Channel

Press Enter to enable or disable CnChip SATA Channel.

### On Chip SATA Type

Press Enter to select the SATA type. The optional settings are: Native IDE; RAID; AHCI; Legacy IDE; IDE→AHCI, Hyper Flash and IDE→Hyper Flash.

### Onboard PCI IDE Controller

The optional settings are Disabled; Primary ; Secondary and Both.

### SATA IDE Combined Mode

The optional settings are : Enabled; Disabled.

### PATA Channel Config

The optional settings are: SATA as Primary and SATA as Secondary.

### Onboard PCI IDE Controller

The optional settings are: Disabled; Primary; Secondary and Both.

Disabled: to disabled the integrated IDE controller;

Primary: to enable only the primary IDE controller;

Secondary: to enable only the secondary IDE controller;

Both: to enable both IDE controllers.

## OnChip Device Control

CMOS Setup Utility-Copyright(C)1985-2005 American Megatrends. Inc.

### OnChip Device Control

Onboard PCIE LAN Device	Enabled	Help Item
Onboard PCIE Lan BootRom	Disabled	
HD Audio Azalia Device	Enable	Options
Azalia Front Panel	Auto	Disabled
USB configuration	Press Enter	Enabled
↑↓→← Move Enter:Select +/-/PU/PD:Value F10:Save ESC:Exit F1:General Help F5: Previous Values F6: Fail-Safe Defaults F7: Optimal Defaults		

### Onboard PCI E Lan

Use this item to enable or disable Onboard PCI E Lan

### HD Audio Azalia Device

This item allows you to decide to enable/disable the chipset family to support HD Audio.The optional settings ar: Auto; Enabled and Disabled.

### USB Configuration

Press Enter to set values for sub-items as: Legacy USB Support, USB 2.0 Controller Mode BIOS EHCI Hand-off etc..

## Super IO Configuration

CMOS Setup Utility-Copyright(C)1985-2005 American Megatrends. Inc.

### Super IO Configuration

Configure F71887F Super IO Chipset		Help Item
Onboard Floppy Controller	Enabled	Select the ACPI State used for system suspend.
Serial Port 1 Address	3F8/IRQ4	
IrDA Mode Select	IrDA(1.6 us)	
IrDA Duplex Mode	Half Duplex	
IRTX Pin Select	Normal	
IRRX Pin Select	Normal	
IRTX to RX peplex Select	No Delay	
IRRX to TX Delay Select	No Delay	
↑↓→← Move Enter:Select +/-/PU/PD:Value F10:Save ESC:Exit F1:General Help F5: Previous Values F6: Fail-Safe Defaults F7: Optimal Defaults		

### Onboard Floppy Controller

Select Enabled if your system has a floppy disk controller (FDD) installed on the system board and you wish to use it. If you install add-on FDC or the system has no floppy drive, select Disabled in this field. The settings are: Enabled and Disabled.

### Serial Port1 Address

Use this item to select serial port address for serial port one.

### IrDA Mode Select

This item allows BIOS to select mode for serial port 2.

The optional settings are: IrDA(1.6 ns) and IrDA (3/16 bit).

### IrDA Duplex Mode

This item allows BIOS to select full or half duplex for serial port 2(IR Mode).The optional settings are: Full Duplex; Half Duplex.

**IrTX Pin Select**

The optional settings are: Normal and Inverse.

This item allows BIOS to select transmit pin in a normal condition or inverse the IRTX(IR Mode).

**IrRX Pin Select**

The optional settings are: Normal and Inverse.

This item allows BIOS to select receiver pin in normal condition or inverse the IRRX(IR mode).

**IRTX to RX Delay Select**

The optional settings are: No Delay and Reception Delay.

This item allows BIOS to select IR from RX to TX 4 characters time delay for serial port2(IR mode)

**IRRX to TX Delay Select**

The optional settings are: No Delay and Transmission Delay.

**Power Management Setup**

The Power Management Setup allows you to configure your system to most effectively save energy saving while operating in a manner consistent with your own style of computer use.

CMOS Setup Utility-Copyright(C)1985-2005 American Megatrends. Inc.  
Power Management Setup

Power Management Feature		Help Item
Suspend Mode	S1 (POS)	
Power management/APM	Enabled	
Suspend Time Out	Disabled	Disable/Enable
Power Button Mode	On/Off	RTC to generate a wake event
Video Power Down Mode	Suspend	
Hard Disk Power Down MODE	Suspend	
Hard Disk Time Out (Minute)	Disabled	
Restore on AC Power Loss	Disabled	
RTC Resume	Disabled	
↑↓→← Move Enter:Select +/-/PU/PD:Value F10:Save ESC:Exit F1:General Help F5: Previous Values F6: Fail-Safe Defaults F7: Optimal Defaults		

**Advanced ACPI Configuration**

Use this section to configure additional ACPI options.

**Power Management/APM**

Use this item to enable or disable AMI based power management and APM support.

**Suspend Time Out**

If it is set Enabled and no activity during this time period, the BIOS will place the system into suspend low power state. The optional settings are: Enable; 1~64 minutes.

**Power Button Mode**

The optional settings are: On/Off; Suspend.

**Video Power Down Mode**

The optional settings are: Disabled; Standby and Suspend.

**Restore on AC Power Loss**

The optional settings are: Disabled; Power on; Power Off and last state.

## Miscellaneous Control

CMOS Setup Utility-Copyright (C)1985-2005 American Megatrends, Inc.  
Miscellaneous Control

Advanced PCI/PnP Setting	Help Item
<p><b>WARNING:</b> Setting wrong values in below sections may cause system to malfunction</p> <p>Clear NVRAM <span style="float: right;">No</span>            Plug &amp; Play O/S <span style="float: right;">No</span>            PCI Latency Timer <span style="float: right;">64</span>            Allocate IRQ to PCI VGA <span style="float: right;">Yes</span>            Palette Snooping <span style="float: right;">Disabled</span>            PCI IDE Bus Master <span style="float: right;">Disabled</span>            Off Board PCI/ISA IDE Card <span style="float: right;">Auto</span>            IRQ Resources <span style="float: right;">Press Enter</span></p>	<p><b>Options</b> Clear NVRAM during System Boot</p>
<p>↑↓→← Move Enter:Select +/-/PU/PD:Value F10:Save ESC:Exit F1:General Help            F5: Previous Values F6: Fail-Safe Defaults F7: Optimal Defaults</p>	

### Plug & Play O/S

The optional settings are: No; Yes

No: Let the BIOS configure all the devices in the system.

Yes: Let the operating system configure Plug and Play devices, not required for boot if your system has a Plug and Play system.

### PCI Latency Timer

Value in units of PCI clocks for PCI device latency timer register.

### Allocate IRQ for PCI VGA

The optional settings are: No; Yes.

Yes: Assigns IRQ to PCI VGA card if card requests IRQ.

No: Does not assign IRQ to PCI VGA card even card requests an IRQ.

### Palette Snooping

The optional settings are: Enabled; Disabled.

Enable: inform the PCI device that an ISA graphics devices is installed in the system so the card will function correctly.

### PCI IDE Bus Master

The optional settings are: Enabled; Disabled.

Enable: BIOS uses PCI busmastering for reading/writing IDE devices.

### Offboard PCI/ISA IDE Card

Some PCI IDE cards may require this to be set to the PCI slot number that is holding the card.

## PC Health Status

This section shows the Status of you CPU, Fan, and Warning for overall system status. This is only available if there is Hardware Monitor onboard.

CMOS Setup Utility-Copyright(C)1985-2005 American Megatrends. Inc.  
PC Health Status

PC Health Status		Help Item
Smart FAN Configuration	Press Enter	
H/W Health Function	Enabled	
NB Case Temperature	44°C/111°F	
Mainboard Temperature	37°C/198°F	
Fan1 Speed	2923RPM	
Fan2 Speed	N/A	
Fan3 Speed	N/A	
VIN1	1.320V	
VIN2	1.136V	
VIN3	4.788V	
VIN4	11.968V	
VIN5	4.956V	
VIN6	1.568V	
↑↓→← Move Enter:Select +/-/PU/PD:Value F10:Save ESC:Exit F1:General Help F5: Previous Values F6: Fail-Safe Defaults F7: Optimal Defaults		

### H/W Health Function,

it displays information list below when set as below. The choice is either Enabled or Disabled.

### CPU Temperature/ System Temperature/CPUFAN/SYSFAN1 Speed/SYSFAN2 Speed /NB1.2V/VDIMM/VCORE/NBPCIE

This will show the CPU/ /System voltage chart and FAN Speed, etc.

## Smart FAN Configuration

CMOS Setup Utility-Copyright(C)1985-2005 American Megatrends. Inc.  
Smart FAN Configuration

FAN1 Mode Setting	Auto Fan by RPM	Help Item
Temperature1 Limit of Hig	050	
Temperature1 Limit of Sec	040	
Temperature1 Limit of Thi	030	
Temperature1 Limit of Low	020	
FAN1 Highest Setting	100	
FAN1 Second Setting	080	
FAN1 Third Setting	070	
FAN1 Forth Setting	060	
FAN1 Lowest Setting	050	
↑↓→← Move Enter:Select +/-/PU/PD:Value F10:Save ESC:Exit F1:General Help F5: Previous Values F6: Fail-Safe Defaults F7: Optimal Defaults		

### Smart FAN Configurations FAN1 Mode Setting

The optional settings are: Auto Fan by RPM; Auto Fan by Dutycycle; Manual Mode by RPM and Manual Mode by Dutycycle.

## Thermal Throttling Options

CMOS

Utility-Copyright (C) 1985-2005 American Megatrends. Inc.  
Thermal Throttling Options

CPU Thermal-Throttling	Enabled	Help Item
CPU Throttling Temp	70°C	
CPU Throttling Duty	50%	
		Options
		Disabled
		Enabled
↑↓→← Move Enter:Select +/-/PU/PD:Value F10:Save ESC:Exit F1:General Help F5: Previous Values F6: Fail-Safe Defaults F7: Optimal Defaults		

### CPU Thermal Throttling

Use this item to enable or disable CPU thermal Throttling. The optional settings are: Enable; Disabled. When set as Enabled, the two following items will show.

#### CPU Thermal Throttling Temp.

Use this item to set CPU thermal Throttling temperature. The selectable arrange is from 40 to 100 °C.

#### CPU Thermal Throttling Duty

Use this item to set CPU Thermal Throttling Duty. The selectable range is from: 12.5% to 87.5%.

## Power User Overclock Setting

CMOS Setup Utility-Copyright (C) 1985-2005 American Megatrends. Inc.  
Power User Overclock Setting

AMD Overclocking Configuration		Help Item
Advanced Clock Calibration	Disabled	
CPU/HT Reference Clock (MHz)	200	Options
PCI E Reference Clock (MHz)	100	Disabled
SB Reference Clock (MHz)	100	Auto
Spread Spectrum	Disabled	All Cores
Processor Frequency Multipli	Auto	Per Core
Over Voltage Configuration		
ADD Compatibility	Disabled	
CPU Vcore Adjust	Default	
CPU Vcore-Shift	Default	
Set Memory Voltage	1.61 V	
NB-Core Voltage Setting	1.30V	
NB -PCIE Voltage Setting	1.15V	
NODEQ PCI-X2 HT Link		
Link Speed	Auto	
Link Width	Auto	
CPU-NB FID	Auto	
DRAM Command Rate	2T	
Memory Clock Mode	Auto	
AMD Overclocking Configuration	Press Wnter	
↑↓→← Move Enter:Select +/-/PU/PD:Value F10:Save ESC:Exit F1:General Help F5: Previous Values F6: Fail-Safe Defaults F7: Optimal Defaults		



**Link Speed**

The HyperTransport link will run at this speed if it slower than or equal to system clock and this board is capable

**Link Width**

The HyperTransport link will run at this width.

**AMD Overclocking Configuration**

The optional settings are: Disable; Enabled.

This item tells BIOS whether to use the setup options below this to configure the P-States or whether to configure the P-States automatically.

**CPU/HT Reference Clock**

Use this item to set CPU/HT Reference Clock. The optional setting range is:190~400 MHz.

**PCI E Reference Clock**

The optional setting range is:90~250 MHz.

**SB Reference Clock**

The optional setting range is:90~150 MHz.

**Spread Spectrum**

The optional settings are: Disabled; SRC CLK; CPUHT CLK and All CLK.

**Processor Voltage**

The optional settings are: Auto; 0.800V~1.350V.

**AOD Compatibility**

Choose Enabled means only AMD over drive can adjust voltage

Choose Disabled means only BIOS can adjust voltage

**CPU Vcore 7-Shift**

Use this item to set value in CPU Vcore 7-Shift function. The optional settings are: Defaults and a range from 5% to 35%.

**Set Memory Voltage**

Use this item to set memory voltage. The optional setting rang is from 1.85V to 2.10V.

**NB-Core Voltage Setting**

The optional settings are from 1.20v to 1.35v.

**NB-PCIE Voltage Setting**

The optional settings are from 1.15v to 1.25v.

**Memory Clock Mode**

The optional settings are: Auto; Limit and Manual.

**Password Settings**

CMOS Setup Utility-Copyright (C)1985-2005 American Megatrends. Inc.  
Password Setting

Security Settings	Help Item
Supervisor Password: Not Installed	Install or change the password
User Password: Not Installed	
Change Supervisor Password Press Enter	
Change User Password Press Enter	
Boot Sector Virus Protection Disabled	
↑↓→← Move Enter:Select +/-/PU/PD:Value F10:Save ESC:Exit F1:General Help F5: Previous Values F6: Fail-Safe Defaults F7: Optimal Defaults	

You can set either supervisor or user password, or both of them. The differences are:

**Supervisor password:** Can enter and change the options of the setup menus.

**User password:** Can only enter but do not have the right to change the options of the setup menus. When you select this function, the following message will appear at the center of the screen to assist you in creating a password.

**ENTER PASSWORD:**

Type the password, up to eight characters in length, and press <Enter>. The password typed now will clear any previously entered password from CMOS memory. You will be asked to confirm the password. Type the password again and press <Enter>. You may also press <Esc> to abort the selection and not enter a password.

To disable a password, just press <Enter> when you are prompted to enter the password. A message will confirm that the password will be disabled. Once the password is disabled, the system will boot and you can enter Setup freely.

**PASSWORD DISABLED.**

When a password has been enabled, you will be prompted to enter it every time you try to enter Setup. This prevents an unauthorized person from changing any part of your system configuration.

Additionally, when a password is enabled, you can also require the BIOS to request a password every time your system is rebooted. This would prevent unauthorized use of your computer.

You determine when the password is required within the BIOS Features Setup Menu and its Security option. If the Security option is set to “System”, the password will be required both at boot and at entry to Setup. If set to “Setup”, prompting only occurs when trying to enter Setup.

## Load Optimal Defaults/ Load Standard Defaults

### Load Optimal Defaults

When you press <Enter> on this item, you get a confirmation dialog box with a message similar to:

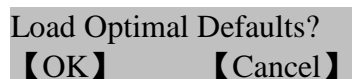

Load Optimal Defaults?  
【OK】      【Cancel】

Pressing <OK> loads the default values that are factory settings for optimal performance system operations.

### Load Standard Defaults

When you press <Enter> on this item, you get a confirmation dialog box with a message similar to:



Load Standard Defaults?  
【OK】      【Cancel】

Pressing <OK> loads the default values that are factory settings for stable performance system operations.



## DRIVER & FREE PROGRAM INSTALLATION

Check your package and there is A MAGIC INSTALL CD included. This CD consists of all DRIVERS you need and some free application programs and utility programs. In addition, this CD also include an auto detect software which can tell you which hardware is installed, and which DRIVERS needed so that your system can function properly. We call this auto detect software MAGIC INSTALL.

### Driver Installation supports Windows 9X/NT/2K/XP/Vista

Insert CD into your CD-ROM drive and the MAGIC INSTALL Menu should appear as below. If the menu does not appear, double-click MY COMPUTER / double-click CD-ROM drive or click START / click RUN / type X:\SETUP.EXE (assuming X is your CD-ROM drive).

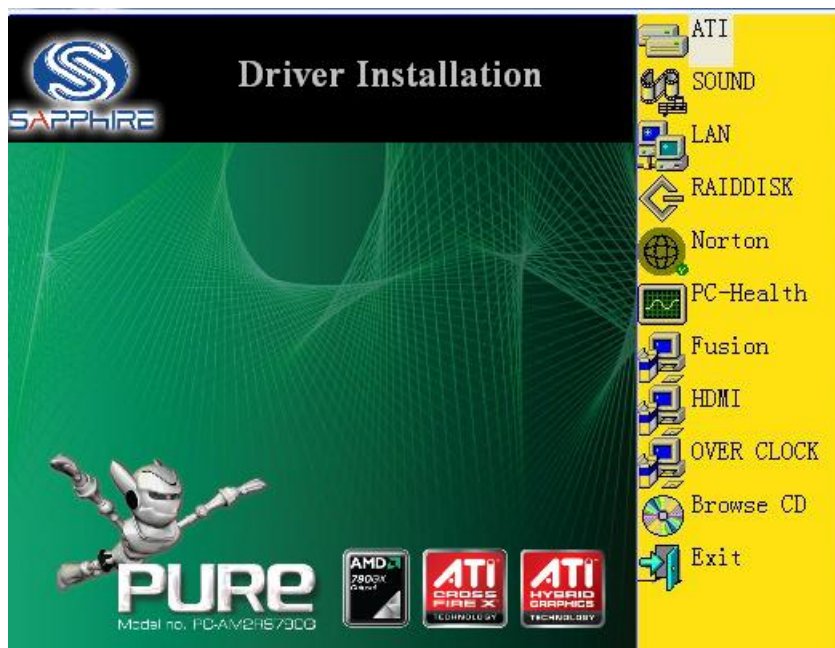

From MAGIC INSTALL MENU you may take 11 selections:

1. ATI to install ATI integrated driver pack
2. Sound to install ALC 888 HD audio codec driver
3. LAN to install Realtek gigabit ethernet NIC driver
4. RAIDDISK to install ATI SATA Driver and Utility
5. Norton to install Norton 2009 Anti-virus Program
6. PC-HEALTH to install MyGuard hardware monitor utility
7. Fusion to download Fusion drives and tools
8. HDMI to install ATI HDMI audio driver
9. OVERCLOCK to install overclock driver utility
10. BROWSE CD to browse the contents of the CD
11. EXIT to exit from MAGIC INSTALL menu

# ATI Integrated Drive Pack

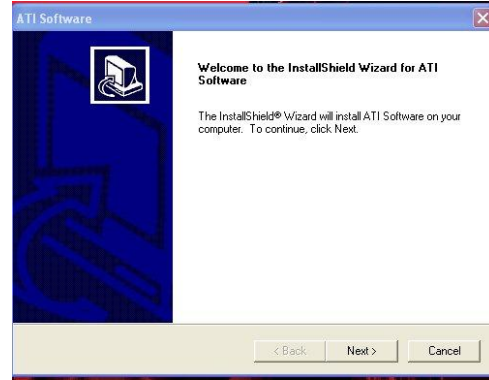
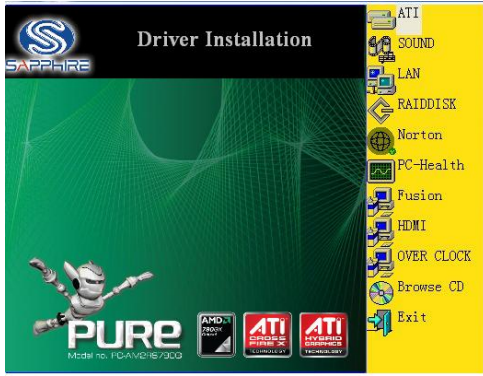

1. Click ATI in the MAGIC INSTALL MENU appears.

2. Click NEXT when ATI software driver pack appears.

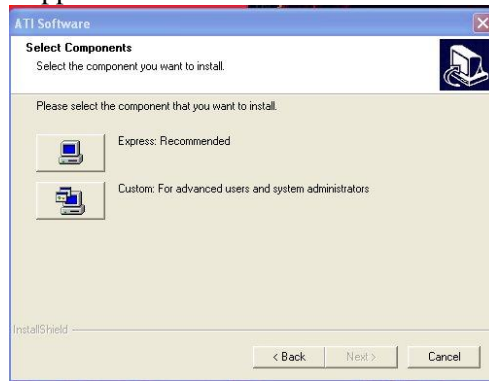
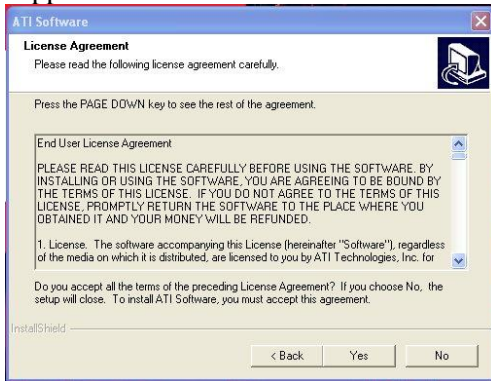

3. Click "Yes" to accept the license agreement and start installation.

4. Select the component you wish to install.



5. When this appears, select Continue Anyway and then wait for the installation process.

6. Choose whether you want to restart the computer and then click Finish.

## Install ALC888 HD Audio Codec Driver



1. Click SOUND when MAGIC INSTALL MENU appears.

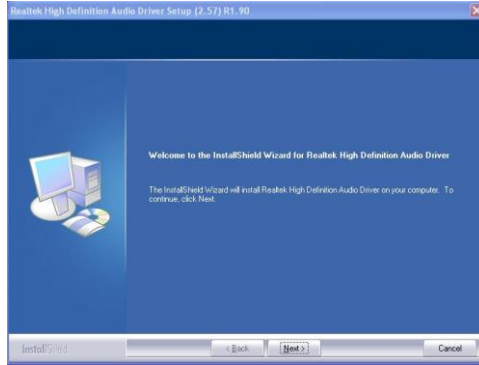

2. Click NEXT When Realtek High Definition Audio driver windows appear.

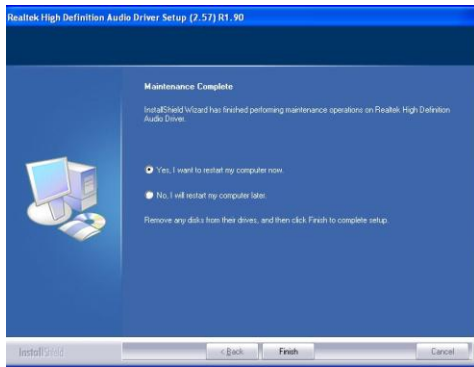

3. Click FINISH and restart your computer.



4. Manual Sound Effect Setting.



5. mixer setting.



6. Audio input and output setting.



7. Microphone effect setting.



8. 3D demo setting.

**NOTE: Please upgrade your Windows XP to Service Pack 1 / Windows 2000 to Service Pack 4 or later before you the HD Audio CODEC driver.**

## Install Realtek Gigabit Ethernet NIC Driver

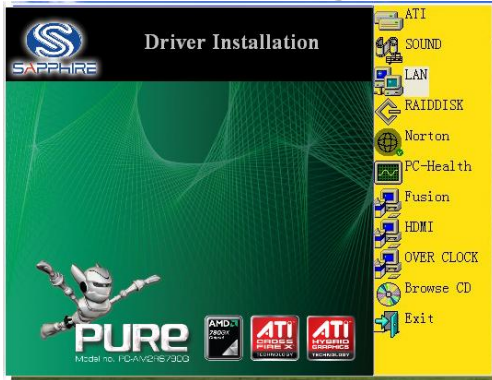

1 Click LAN when Magic Install Menu appears

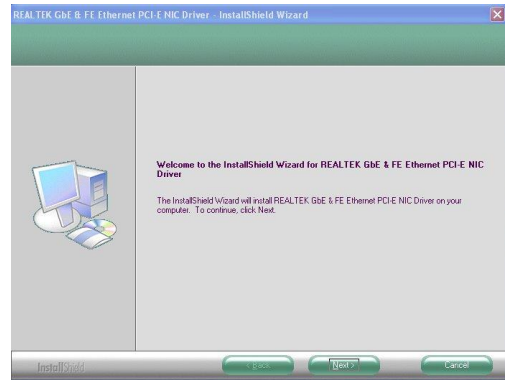

2. Click NEXT, install REALTEK LAN and Fast Ethernet NIC Driver

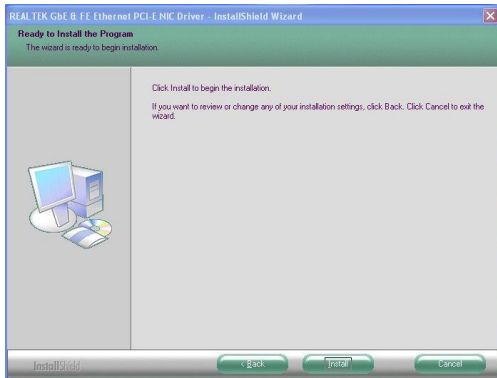

3 Click install to begin the installation.

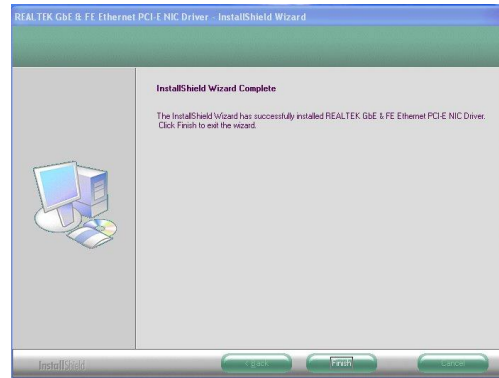

2. After driver installation completed, Click Finish..

## Install ATI SATA Driver and Utility



1 Click RAIDDisk when MAGIC INSTALL MENU appears

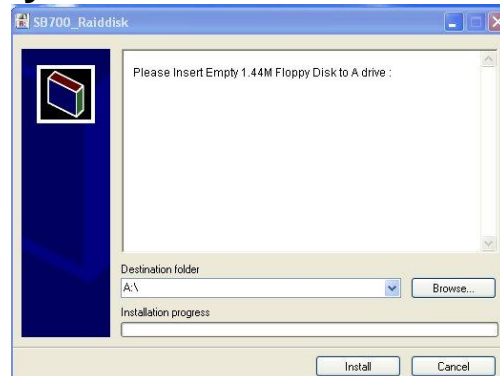

2. Copy the files to floppy disk and restart the computer with floppy disk as the first booting disk and then follow the steps shown on the screen to finish RAID function settings.

## Install Norton 2009 Anti-virus Program

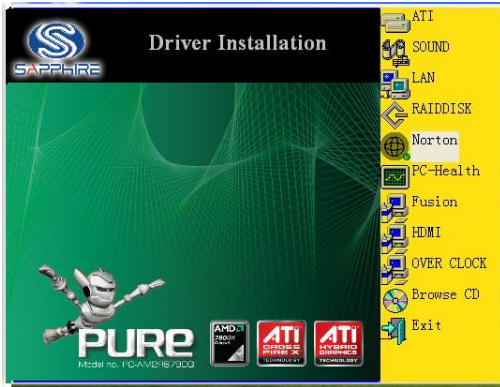

- 1 Click Norton when Magic Install menu appears.
3. Click AGREE & INSTALL after reading User License Agreement.
- 4.

## Install MyGuard Hardware Monitor Utility

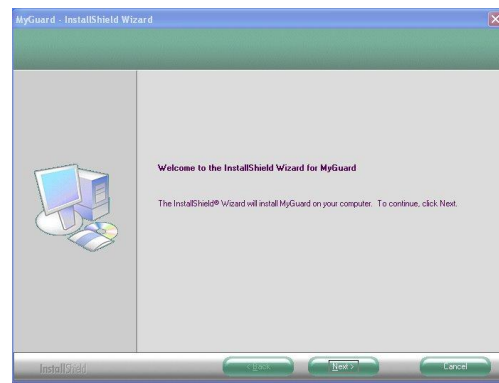
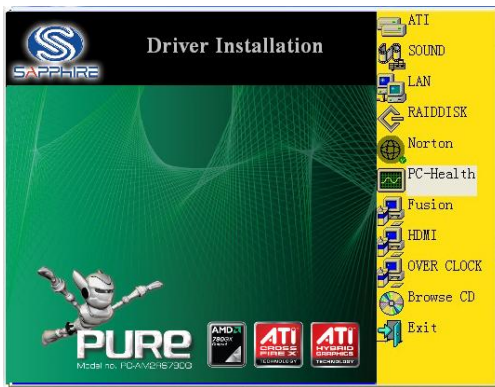

1. Click PC-HEALTH when MAGIC INSTALL MENU appears
2. Click Next on Install shield wizard Window appears

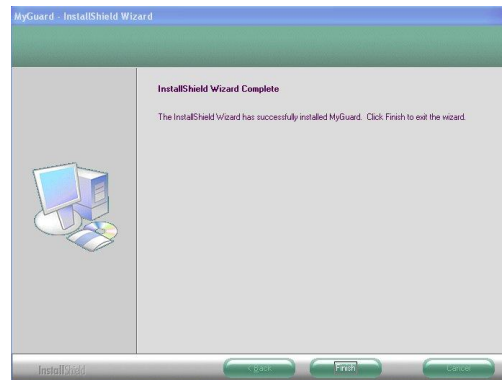
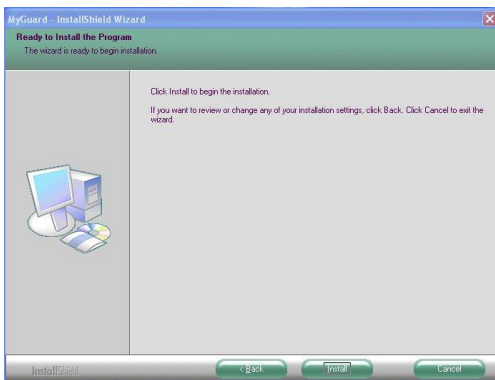

3. Click Install to begin the installation.
4. Click Finish to complete the installation.



## Download Fusion Drivers and Tools

Click Fusion when Magic Install menu appears to visit AMD official website

[http://game.amd.com/us-en/drivers\\_fusion.aspx?p=1](http://game.amd.com/us-en/drivers_fusion.aspx?p=1) to download fusion drivers and tools.

Please make sure that you net is connected well and you operating system is Windows Vista before running downloaded programs.



## Install ATI HDMI Audio Driver

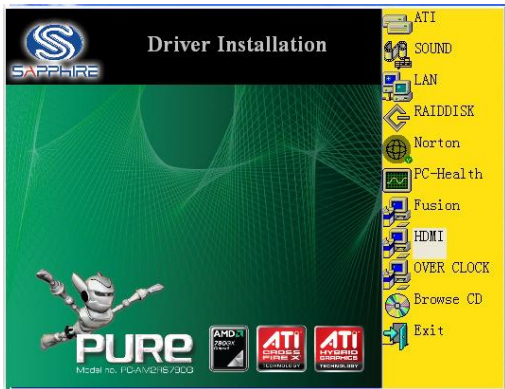

1. Click HDMI when MAGIC INSTALL MENU appears

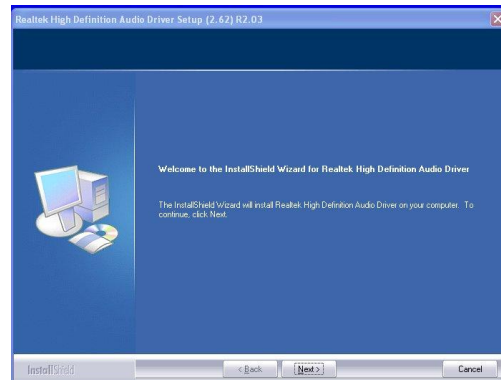

2. Click Next on Install shield wizard Window.

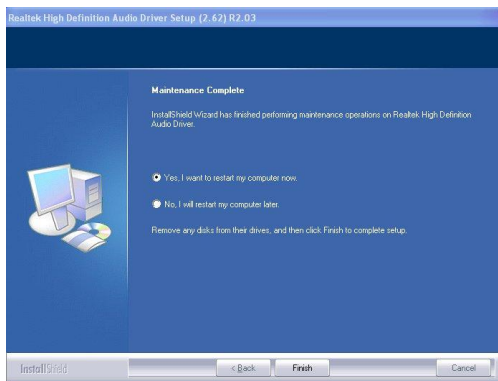

# Install OVERCLOCK Drive Utility

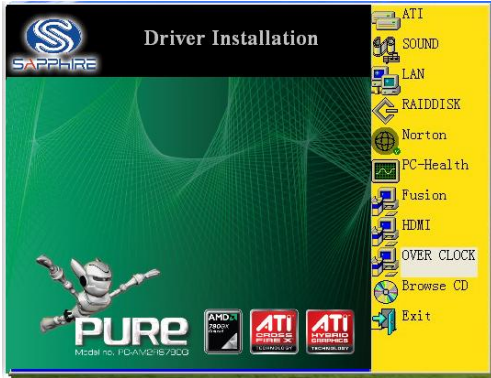

1. Click OVER CLOCK when MAGIC INSTALL MENU appears

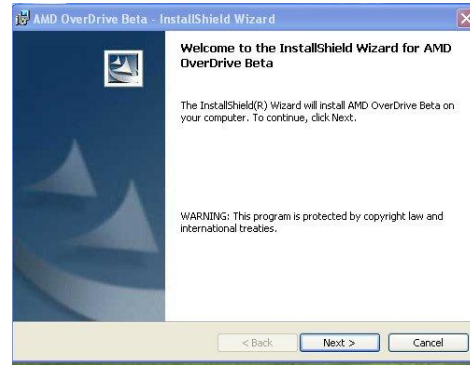

2. Click Next



3. Choose "I accept the terms in the license agreement".

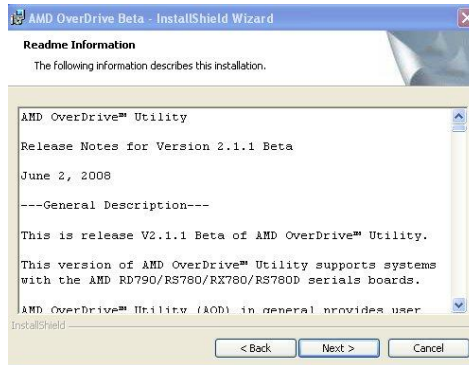

4. The information describe the installation, Click Next

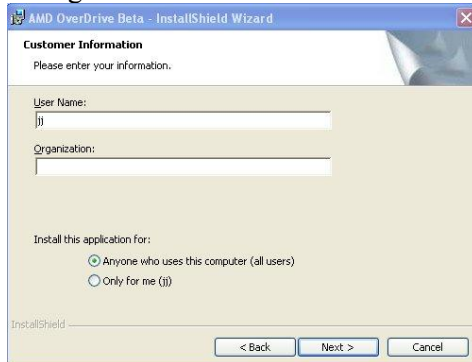

5. Type in Customer Information and then click Next.

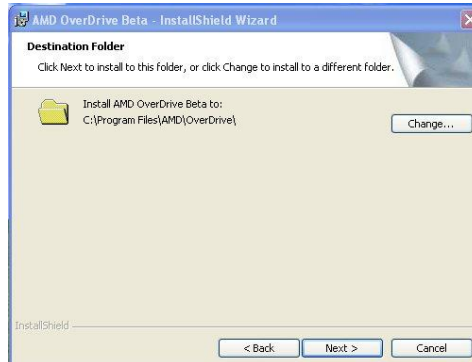

6. Select the Destination Folder and then Click Next.

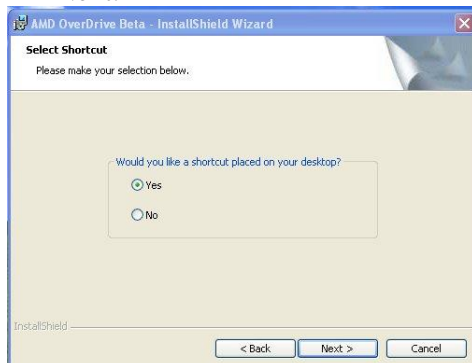

7. Decide whether you want a shortcut on your desktop and then click Next.

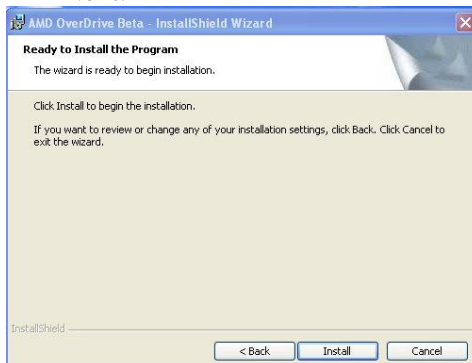

8. Click Install to begin installation.



9. Wait for the installation process.

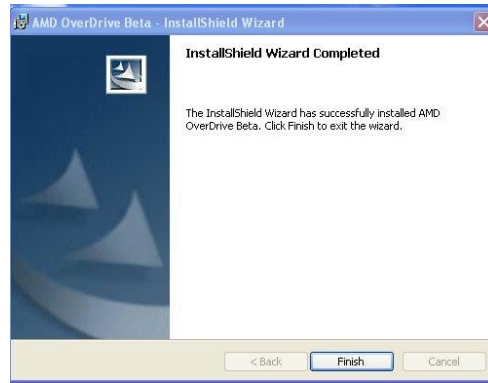

10. Finish the installation.

## AMD Platform RAID Function Installation

Please set these choice in the BIOS as RAID : BIOS setup \Integrated Peripherals \Onboard SATA Device \ Onchip SATA Device. When the below figures appeared, please press [Ctrl-F] into figure 2



[figure1]

Function: press[1] key, showing the RAID; press [2] key , building RAID; press [3] key, delete the RAID; press[4] key, showing the information of controller.

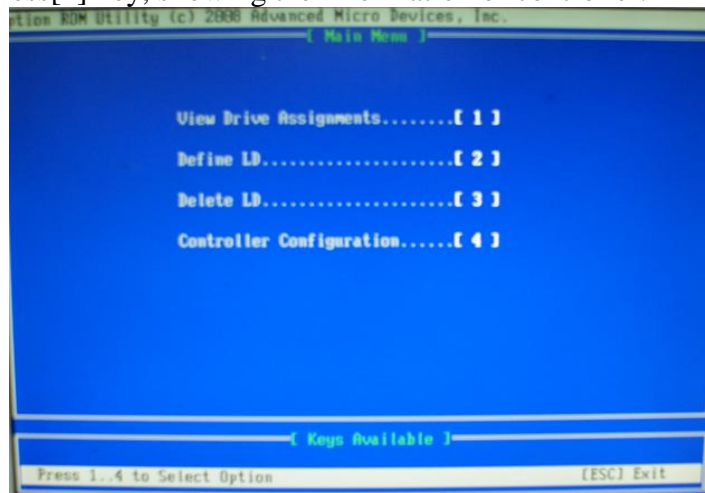

[figure2]

press [1] key , showing the RAID , as the below figure

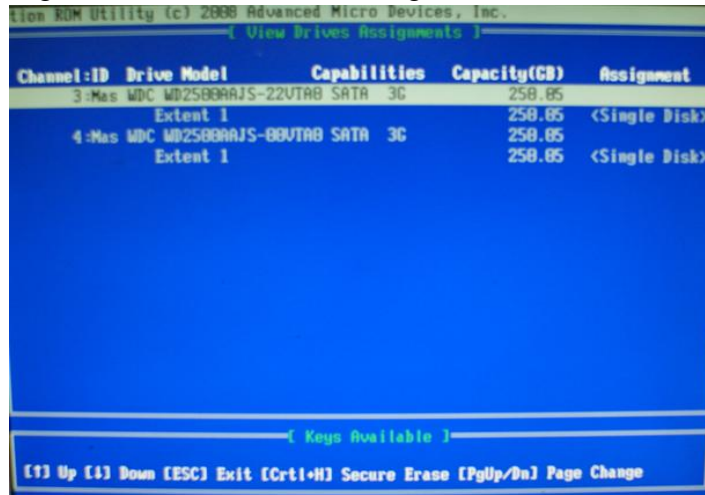

[figure3]

Press [2] key, the interface of RAID, as figure 4.

RAID function:

1. RAID 1      2. RAID 0      3. RAID 10      4. RAID5

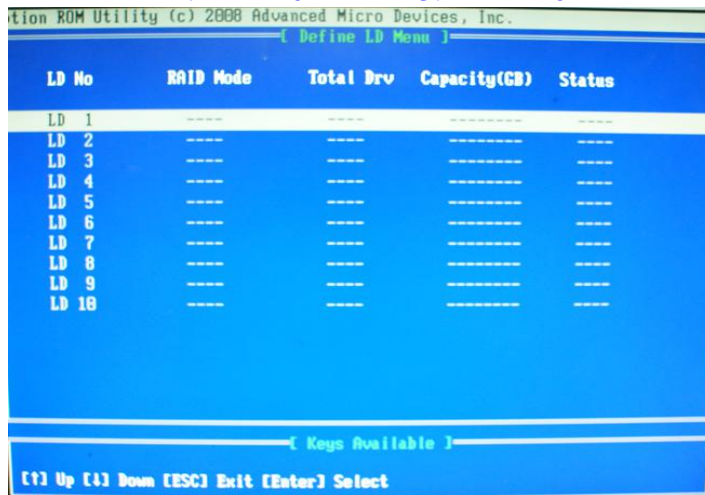

[figure4]

Choose LD 1 then press Enter.

Take Raid0 for example, use [ ↑ ] [ ↓ ] to shift the cursor, press space key to change the choice, press [Ctrl-Y] to keep.

Set Assignment mode as [Y], press [Ctrl-Y] to keep , then figure 5 appeared, erase the MBR. choose [Ctrl-Y],figure 6 appeared. Press any key, finished the RAID.

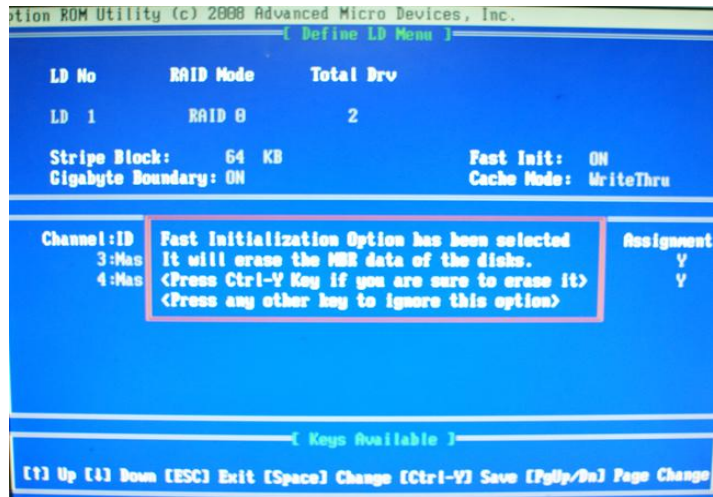

[figure5]

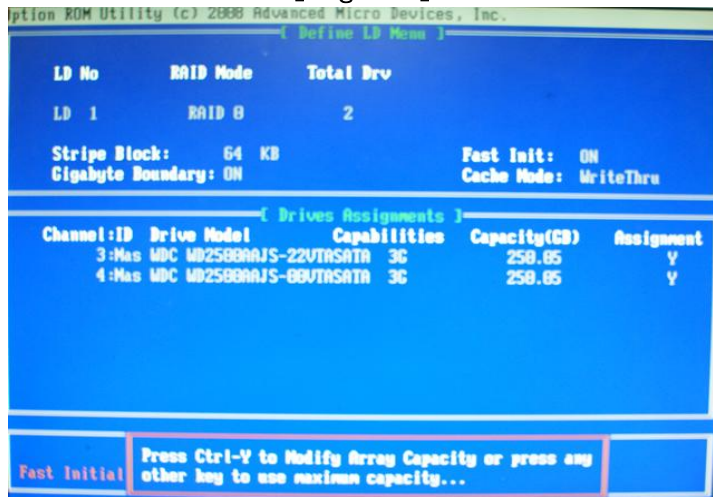

[figure6]

Press [3], delete the RAID mode, as figure 7. press [Delete] will delete the array. As figure 7.

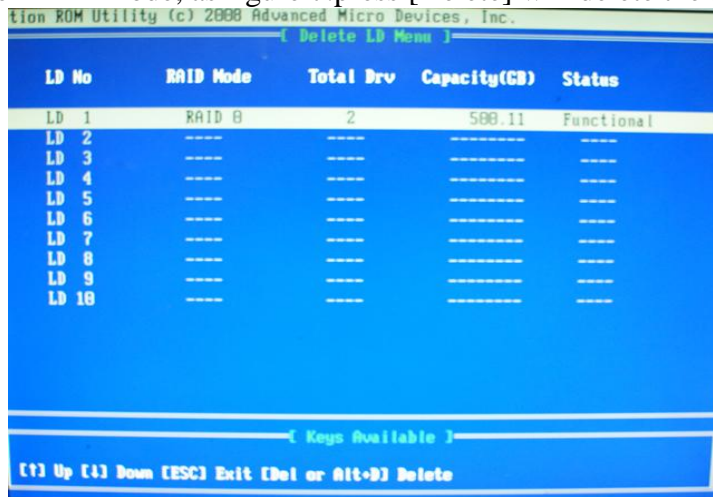

[figure7]

Press [4], showing the information of controller, as figure 8.

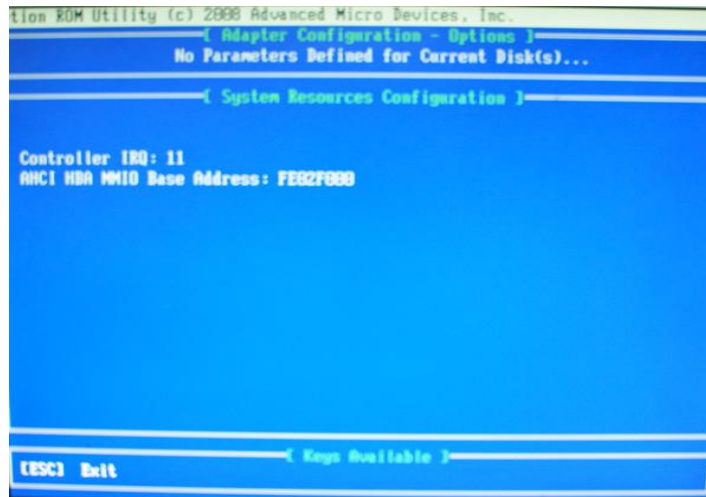

[figure8]

### **Making RAID driver diskette before Install WindowsXP/2000/Vista**

Before you install the Windows XP or Windows 2000, you will need to make a RAID driver diskette before you start to install the Operating System.

#### **How to make a RAID driver diskette?**

- 1: Insert the diskette which is being formatted in floppy drive on a system which can start OS.
- 2: After booting OS insert the bundle CD in your CD-ROM
- 3: Copy all the files from\AMD\RAIDDisk to floppy diskette

Once you have the SATA driver diskette ready, you may start to install Windows XP, Windows 2000 or Vista on your System.

#### **Installation of Windows XP/ 2000/Vista**

For installation of Windows XP, windows 2000 or Vista, please insert Windows XP Windows 2000 or Vista CD into the CD-ROM drive. Then remove the floppy diskette, and boot the system. At the very beginning, you will see the message at the bottom of screen, "Press F6 if you need to install a third party SCSI or RAID driver...."

At this moment, please press <F6> key and follow the instructions of Windows XP or Windows 2000 for the proper installation.

## **Pro Magic Plus Function Introduction**

### **What's Pro Magic Plus?**

Tired with reinstall OS each time when it doesn't work? Does your computer often crash down or unable to work after installed new software? Have you had great losses and troubles because of computer problems? Still using time-consuming backup software that occupies lots of HD space?

Pro Magic Plus- an instant system recovery software tailored to solve these problems for you. It combines various application tools (e.g. anti-virus, backup software, uninstall software, multi-boot software) to satisfy your needs of all sorts of system protections.

### **What functions does Pro Magic Plus have?**

1. **Instant System Restoration** – Regardless of mis-operation or system crash, install Pro

Magic Plus beforehand would allow you to instantly restore your system back by simply reboot your computer.

2. **Easy-to-use** – Auto installation from CD ROM; Supports Mouse
3. **System Uninstall** – Pro Magic provides a protection mode, which allows user to freely test any software. If user does not want to keep the software, just reboot the computer to restore back to the previous state, and Pro Magic will remove it completely from you computer.
4. **Password Security** – Pro Magic provides double password protection, including user password for entering each OS and manager password for managing 'Pro Magic', which can effectively prevent others from using your computer without permission or data from being stolen. (disable item for OEM version)
5. **Complete Protection** – Pro Magic not only protects the system disk, but also can protect your data disk, and does not require to reboot when backup or restore data disk.
6. **Multipoint Save/Restore** – You can backup your system whenever you need and restore them back to anytime you wish, 1 hour, 1 day or 1 month ago. Restore points are unlimited. (disable item for OEM version)
7. **Data Disk Protection** – Pro Magic Plus now comes with data disk protection, provides complete protection for your computer! (disable item for OEM version)
8. **You can choose to change the default path of 'My Document', 'My Favorite' and 'Outlook Express'**, so that when you are restoring the system, data in these folders will not be restored as well. (This is optional, you can leave it as it is).

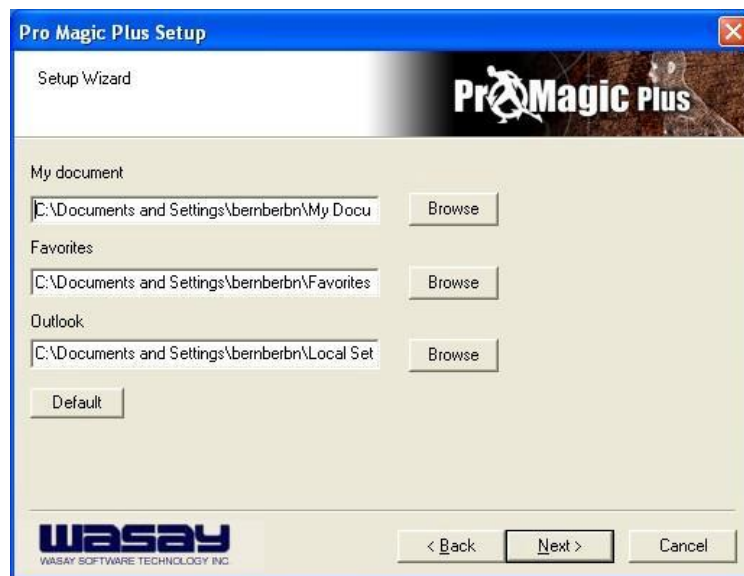

graph 4

NOTE: Functions of each version will differ from each other, and will be based on the function descriptions of each version.

### System Requirements

- ◇ First OS must be Windows 2000/XP/Vista
- ◇ Support Only Windows OS (No Linux)
- ◇ Windows server OS and Windows NT not supported
- ◇ Minimum of Intel 486 or above, 16MB of memory or above
- ◇ Minimum of 500MB free/usable space or above
- ◇ Support for SCSI & SATA Hard disk

*Pro Magic Plus only supports SCSI hard disk with Windows 2000 or OS above*

## Notice Before Installation

1. Before install Pro Magic Plus, turn off all anti-virus software. (Include BIOS anti-virus function)
2. Pro Magic Plus does not support multiple PRI partitions. If you have multiple PRI partitions, please repartition your HD before installation.
3. If your HDD is not fully partitioned (with un-partitioned/unused space at end of HDD), please repartition the HDD before install Pro Magic Plus.

## USEFUL HELP

### How to Update BIOS

**STEP 1.** Prepare a bootable floppy disk. (You may make one by click START click RUN type SYS A: click OK)

**STEP 2.** Download upgrade tools and the latest BIOS files of the motherboard from official website and then make a copy of it to your bootable floppy disk after decompressing these files

**STEP 3.** Insert the disk into A: ,start your computer and then type in  
“A:\xxxxxx.BAT”(xxxxxxx being the file name of the latest BIOS )

**STEP 4.** Type Enter to update and flash the BIOS. The system will restart automatically when BIOS is upgraded.

### Trouble Shooting

Problem	Solution
No power to the system to the all power light don't illuminate, fan inside power supply doesn't turn on.	1. Make sure power cable is security plugged in. 2. Replace cable. 3. Contact technical support.
System inoperative. Keyboard lights are on , power indicator lights are lit, and hard drive is spinning.	Using ever pressure on both ends of the DIMM , press down firmly until the module snaps into places.
System doesn't boot from hard disk drive, can be booted from optical drive.	1. Check cable running from disk to disk controller board. .Make sure both ends are securely plugged in, check the drive type in the standard CMOS setup. 2. Backing up the hard drive is extremely important .All hard disks are capable of breaking down at any time.
System only boots from optical drive .Hard disk can be read and applications can be used but booting from hard disk is impossible.	1. Back up date and applications files. 2. Reformat the hard drive. Reinstall applications and date using backup disks.
Screen message says “Invalid Configuration” or “CMOS Failure”	Review system 's equipment .Make sure correct information on is in setup.
Can not boot system after installing second hard drive.	1. Set master /slave jumpers correctly. 2. Run SETUP program and select correct drive types. Call the drive manufacture for compatibility with other drives.



## Post BIOS Beep Code ( for AMI BIOS use )

Number of Beeps	Description
1	Memory refresh timer error.
2	Parity error in base memory (first 64KB block)
3	Base memory read/write test error
4	Motherboard timer not operational
5	Processor error
6	8042 Gate A20 test error (cannot switch to protected mode)
7	General exception error (processor exception interrupt error)
8	Display memory error (system video adapter)
9	AMIBIOS ROM checksum error
10	CMOS shutdown register read/write error
11	Cache memory test failed

## Debug Port Post Code ( for AMI BIOS use )

### Bootblock Initialization Code Checkpoints

The Bootblock initialization code sets up the chipset, memory and other components before system memory is available. The following table describes the type of checkpoints that may occur during the bootblock initialization portion of the BIOS:

Checkpoint	Description
Before D0	If boot block debugger is enabled, CPU cache-as-RAM functionality is enabled at this point. Stack will be enabled from this point.
D0	Early Boot Strap Processor (BSP) initialization like microcode update, frequency and other CPU critical initialization. Early chipset initialization is done.
D1	Early super I/O initialization is done including RTC and keyboard controller. Serial port is enabled at this point if needed for debugging. NMI is disabled. Perform keyboard controller BAT test. Save power-on CPUID value in scratch CMOS. Go to flat mode with 4GB limit and GA20 enabled.
D2	Verify the boot block checksum. System will hang here if checksum is bad.
D3	Disable CACHE before memory detection. Execute full memory sizing module. If memory sizing module not executed, start memory refresh and do memory sizing in Boot block code. Do additional chipset initialization. Re-enable CACHE. Verify that flat mode is enabled.
D4	Test base 512KB memory. Adjust policies and cache first 8MB. Set stack.
D5	given to it. BIOS now executes out of RAM. Copies compressed boot block code to memory in right segments. Copies BIOS from ROM to RAM for faster

	access. Performs main BIOS checksum and updates recovery status accordingly.
D6	Both key sequence and OEM specific method is checked to determine if BIOS recovery is forced. If BIOS recovery is necessary, control flows to checkpoint E0. See <i>Bootblock Recovery Code Checkpoints</i> section of document for more information.
D7	Restore CPUID value back into register. The Bootblock-Runtime interface module is moved to system memory and control is given to it. Determine whether to execute serial flash.
D8	The Runtime module is uncompressed into memory. CPUID information is stored in memory.
D9	Store the Uncompressed pointer for future use in PMM. Copying Main BIOS into memory. Leaves all RAM below 1MB Read-Write including E000 and F000 shadow areas but closing SMRAM.
DA	Restore CPUID value back into register. Give control to BIOS POST (ExecutePOSTKernel). See <i>POST Code Checkpoints</i> section of document for more information.
DC	System is waking from ACPI S3 state
E1-E8 EC-EE	OEM memory detection/configuration error. This range is reserved for chipset vendors & system manufacturers. The error associated with this value may be different from one platform to the next.

### **Bootblock Recovery Code Checkpoints**

The Bootblock recovery code gets control when the BIOS determines that a BIOS recovery needs to occur because the user has forced the update or the BIOS checksum is corrupt. The following table describes the type of checkpoints that may occur during the Bootblock recovery portion of the BIOS:

Checkpoint	Description
E0	Initialize the floppy controller in the super I/O. Some interrupt vectors are initialized. DMA controller is initialized. 8259 interrupt controller is initialized. L1 cache is enabled.
E9	Set up floppy controller and data. Attempt to read from floppy.
EA	Enable ATAPI hardware. Attempt to read from ARMD and ATAPI CDROM.
EB	Disable ATAPI hardware. Jump back to checkpoint E9.
EF	Read error occurred on media. Jump back to checkpoint EB.
F0	Search for pre-defined recovery file name in root directory.
F1	Recovery file not found.
F2	Start reading FAT table and analyze FAT to find the clusters occupied by the recovery file.
F3	Start reading the recovery file cluster by cluster.
F5	Disable L1 cache.

FA	Check the validity of the recovery file configuration to the current configuration of the flash part.
FB	Make flash write enabled through chipset and OEM specific method. Detect proper flash part. Verify that the found flash part size equals the recovery file size.
F4	The recovery file size does not equal the found flash part size.
FC	Erase the flash part.
FD	Program the flash part.
FF	The flash has been updated successfully. Make flash write disabled. Disable ATAPI hardware. Restore CPUID value back into register. Give control to F000 ROM at F000:FFF0h.

### **POST Code Checkpoints**

The POST code checkpoints are the largest set of checkpoints during the BIOS preboot process. The following table describes the type of checkpoints that may occur during the POST portion of the BIOS:

Checkpoint	Description
03	Disable NMI, Parity, video for EGA, and DMA controllers. Initialize BIOS, POST, Runtime data area. Also initialize BIOS modules on POST entry and GPNV area. Initialize CMOS as mentioned in the Kernel Variable "wCMOSFlags."
04	Check CMOS diagnostic byte to determine if battery power is OK and CMOS checksum is OK. Verify CMOS checksum manually by reading storage area. If the CMOS checksum is bad, update CMOS with power-on default values and clear passwords. Initialize status register A.  Initializes data variables that are based on CMOS setup questions. Initializes both the 8259 compatible PICs in the system
05	Initializes the interrupt controlling hardware (generally PIC) and interrupt vector table.
06	Do R/W test to CH-2 count reg. Initialize CH-0 as system timer. Install the POSTINT1Ch handler. Enable IRQ-0 in PIC for system timer interrupt. Traps INT1Ch vector to "POSTINT1ChHandlerBlock."
07	Fixes CPU POST interface calling pointer.
08	Initializes the CPU. The BAT test is being done on KBC. Program the keyboard controller command byte is being done after Auto detection of KB/MS using AMI KB-5.
C0	Early CPU Init Start -- Disable Cache -- Init Local APIC
C1	Set up boot strap processor Information
C2	Set up boot strap processor for POST
C5	Enumerate and set up application processors
C6	Re-enable cache for boot strap processor

C7	Early CPU Init Exit
0A	Initializes the 8042 compatible Key Board Controller.
0B	Detects the presence of PS/2 mouse.
0C	Detects the presence of Keyboard in KBC port.
0E	Testing and initialization of different Input Devices. Also, update the Kernel Variables. Traps the INT09h vector, so that the POST INT09h handler gets control for IRQ1. Uncompress all available language, BIOS logo, and Silent logo modules.
13	Early POST initialization of chipset registers.
20	Relocate System Management Interrupt vector for all CPU in the system.
24	Uncompress and initialize any platform specific BIOS modules. GPNV is initialized at this checkpoint.
2A	Initializes different devices through DIM. See <i>DIM Code Checkpoints</i> section of document for more information.
2C	Initializes different devices. Detects and initializes the video adapter installed in the system that have optional ROMs.
2E	Initializes all the output devices.
31	Allocate memory for ADM module and uncompress it. Give control to ADM module for initialization. Initialize language and font modules for ADM. Activate ADM module.
33	Initializes the silent boot module. Set the window for displaying text information.
37	Displaying sign-on message, CPU information, setup key message, and any OEM specific information.
38	Initializes different devices through DIM. See <i>DIM Code Checkpoints</i> section of document for more information. USB controllers are initialized at this point.
39	Initializes DMAC-1 & DMAC-2.
3A	Initialize RTC date/time.
3B	Test for total memory installed in the system. Also, Check for DEL or ESC keys to limit memory test. Display total memory in the system.
3C	Mid POST initialization of chipset registers.
40	Detect different devices (Parallel ports, serial ports, and coprocessor in CPU, ... etc.) successfully installed in the system and update the BDA, EBDA...etc.
52	Updates CMOS memory size from memory found in memory test. Allocates memory for Extended BIOS Data Area from base memory. Programming the memory hole or any kind of implementation that needs an adjustment in system RAM size if needed.
60	Initializes NUM-LOCK status and programs the KBD typematic rate.

75	Initialize Int-13 and prepare for IPL detection.
78	Initializes IPL devices controlled by BIOS and option ROMs.
7C	Generate and write contents of ESCD in NVRam.
84	Log errors encountered during POST.
85	Display errors to the user and gets the user response for error.
87	Execute BIOS setup if needed / requested. Check boot password if installed.
8C	Late POST initialization of chipset registers.
8D	Build ACPI tables (if ACPI is supported)
8E	Program the peripheral parameters. Enable/Disable NMI as selected
90	Initialization of system management interrupt by invoking all handlers. <i>Please note this checkpoint comes right after checkpoint 20h</i>
A1	Clean-up work needed before booting to OS
A2	Takes care of runtime image preparation for different BIOS modules. Fill the free area in F000h segment with 0FFh. Initializes the Microsoft IRQ Routing Table. Prepares the runtime language module. Disables the system configuration display if needed.
A4	Initialize runtime language module. Display boot option popup menu.
A7	Displays the system configuration screen if enabled. Initialize the CPU's before boot, which includes the programming of the MTRR's.
A9	Wait for user input at config display if needed.
AA	Uninstall POST INT1Ch vector and INT09h vector
AB	Prepare BBS for Int 19 boot. Init MP tables.
AC	End of POST initialization of chipset registers. De-initializes the ADM module.
B1	Save system context for ACPI. Prepare CPU for OS boot including final MTRR values.
00	Passes control to OS Loader (typically INT19h).

## OEM POST Error Checkpoints

Checkpoints from the range 61h to 70h are reserved for chipset vendors & system manufacturers. The error associated with this value may be different from one platform to the next.

### DIM Code Checkpoints

The Device Initialization Manager (DIM) gets control at various times during BIOS POST to initialize different system busses. The following table describes the main

checkpoints where the DIM module is accessed:

Checkpoint	Description
2A	Initialize different buses and perform the following functions: Reset, Detect, and Disable (function 0); Static Device Initialization (function 1); Boot Output Device Initialization (function 2). Function 0 disables all device nodes, PCI devices, and PnP ISA cards. It also assigns PCI bus numbers. Function 1 initializes all static devices that include manual configured onboard peripherals, memory and I/O decode windows in PCIPCI bridges, and noncompliant PCI devices. Static resources are also reserved. Function 2 searches for and initializes any PnP, PCI, or AGP video devices.
38	Initialize different buses and perform the following functions: Boot Input Device Initialization (function 3); IPL Device Initialization (function 4); General Device Initialization (function 5). Function 3 searches for and configures PCI input devices and detects if system has standard keyboard controller. Function 4 searches for and configures all PnP and PCI boot devices. Function 5 configures all onboard peripherals that are set to an automatic configuration and configures all remaining PnP and PCI devices.

While control is in the different functions, additional checkpoints are output to port 80h as a word value to identify the routines under execution. The low byte value indicates the main POST Code Checkpoint. The high byte is divided into two nibbles and contains two fields. The details of the high byte of these checkpoints are as follows:

**HIGH BYTE XY**

The upper nibble 'X' indicates the function number that is being executed. 'X' can be from 0 to 7.

- 0 = func#0, disable all devices on the BUS concerned.
- 1 = func#1, static devices initialization on the BUS concerned.
- 2 = func#2, output device initialization on the BUS concerned.
- 3 = func#3, input device initialization on the BUS concerned.
- 4 = func#4, IPL device initialization on the BUS concerned.
- 5 = func#5, general device initialization on the BUS concerned.
- 6 = func#6, error reporting for the BUS concerned.
- 7 = func#7, add-on ROM initialization for all BUSes.
- 8 = func#8, BBS ROM initialization for all BUSes.

The lower nibble 'Y' indicates the BUS on which the different routines are being executed. 'Y' can be from 0 to 5.

- 0 = Generic DIM (Device Initialization Manager).
- 1 = On-board System devices.

- 2 = ISA devices.
- 3 = EISA devices.
- 4 = ISA PnP devices.
- 5 = PCI devices.

### **ACPI Runtime Checkpoints**

ACPI checkpoints are displayed when an ACPI capable operating system either enters or leaves a sleep state. The following table describes the type of checkpoints that may occur during ACPI sleep or wake events:

Checkpoint	Description
AC	First ASL check point. Indicates the system is running in ACPI mode.
AA	System is running in APIC mode.
01,02,03,04,05	Entering sleep state S1, S2, S3, S4, or S5.
10,20,30,40,50	Waking from sleep state S1, S2, S3, S4, or S5.

## **Glossary**

**Chipset (or core logic)** - two or more integrated circuits which control the interfaces between the system processor, RAM, I/O devices, and adapter cards.

**Processor socket** - the socket used to mount the system processor on the motherboard.

**Slot (PCI-E, PCI, RAM)** - the slots used to mount adapter cards and system RAM.

**PCI - Peripheral Component Interconnect** - a high speed interface for video cards, sound cards, network interface cards, and modems; runs at 33MHz.

**PCI Express2.0-** Peripheral Component Interconnect Express2.0, developed in 2003, the speed of each line doubled from the previous PCI-E of 2.5 Gbps to 5 Gbps.

**Serial Port** - a low speed interface typically used for mouse and external modems.

**Parallel Port** - a low speed interface typically used for printers.

**PS/2** - a low speed interface used for mouse and keyboards.

**USB - Universal Serial Bus** - a medium speed interface typically used for mouse, keyboards, scanners, and some digital cameras.

**Sound (interface)** - the interface between the sound card or integrated sound connectors and speakers, MIC, game controllers, and MIDI sound devices.

**LAN (interface) - Local Area Network** - the interface to your local area network.

**BIOS (Basic Input/Output System)** - the program logic used to boot up a computer and establish the relationship between the various components.

**Driver** - software, which defines the characteristics of a device for use by another device or other software.

**Processor** - the "central processing unit" (CPU); the principal integrated circuit used for doing the "computing" in "personal computer"

**Front Side Bus Frequency** - the working frequency of the motherboard, which is generated by the clock generator for CPU, DRAM and PCI BUS.

**CPU L2 Cache** - the flash memory inside the CPU, normal it depend on CPU type.